

Non-Welded Grease Duct/Chimney Systems

Installation, Operation, and Maintenance Manual

Grease Duct

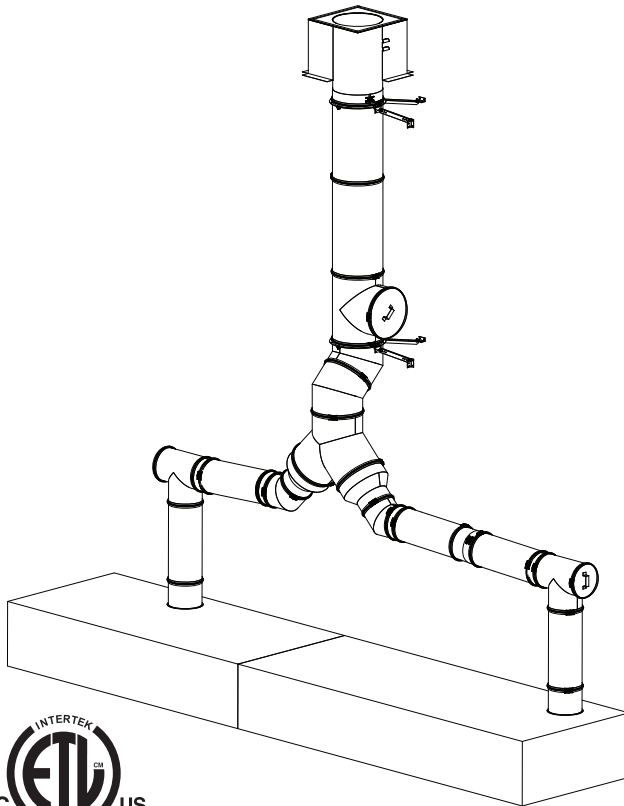

Chimney

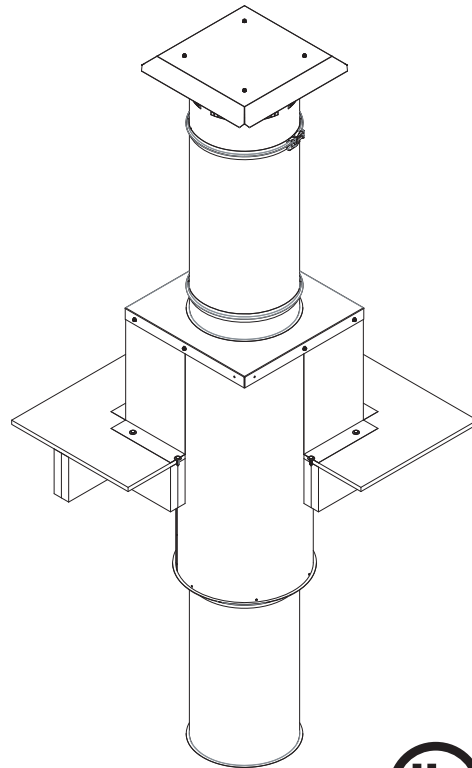

FOR YOUR SAFETY

TWO MAJOR CAUSES OF GREASE DUCT RELATED FIRES: (1) FAILURE TO MAINTAIN REQUIRED CLEARANCE (AIR SPACE) TO COMBUSTIBLE MATERIALS AND (2) FAILURE TO CLEAN GREASE LADEN DUCTS. MAJOR CAUSES OF CHIMNEY SYSTEM RELATED FIRES IS DUE TO THE BUILD UP OF CREOSOTE. CHIMNEY SYSTEMS SHOULD BE INSPECTED ONCE EVERY TWO MONTHS, CREOSOTE AND SOOT SHOULD BE REMOVED TO REDUCE THE RISK OF FIRE. IT IS OF UTMOST IMPORTANCE THAT THIS GREASE DUCT / CHIMNEY SYSTEM BE INSTALLED ONLY IN ACCORDANCE WITH THESE INSTRUCTIONS. DO NOT INSTALL GREASE DUCT / CHIMNEY SYSTEMS WITHOUT FIRST READING THESE INSTRUCTIONS VERY CAREFULLY.

RECEIVING AND INSPECTION

EXAMINE ALL COMPONENTS FOR POSSIBLE SHIPPING DAMAGE PRIOR TO INSTALLATION. DIFFERENT MANUFACTURERS HAVE DIFFERENT JOINT SYSTEMS AND ADHESIVES. DO NOT MIX PIPE, FITTINGS, OR JOINING METHODS FROM DIFFERENT MANUFACTURERS.

Save these instructions. This document is the property of the owner of this equipment and is required for future maintenance. Leave this document with the owner when installation or service is complete.

Table of Contents

WARRANTY	4
LISTINGS	5
APPLICATION	6
Grease Duct	6
Chimneys	7
MECHANICAL	8
Joint Sealant	8
Grease Duct & Chimney Joint Assembly	9
Single Wall Collar and Adjustable Grease Duct/Chimney Connections	10
Single Wall Collar and Adjustable Grease Duct/Chimney Vertical Installation	11
Single Wall Offset Distance	12
Clearances - Grease Duct	15
Zero Clearances to Combustibles	15
Clearances - Chimney	16
Single Wall Chimney Supports	18
Single Wall Chimney Annular Distance and Clearance	19
Factory and Field (Bolted and Welded) Risers	20
Duct/Chimney Drains	21
Chimney Drain Trap Loop	21
Grease Manifold Tee	22
Access Door (Tee Cap) Assembly	23
Transition Plate	24
Prevention of Grease Accumulation in Horizontal Grease Duct	24
Chimney Transition Plate	25
Alignment and Bracing of Grease Duct/Chimney	25
Horizontal Support and Support Spacing	26
Single Wall Vertical Support Spacing and Wall Guide Support	27
Single Wall Vertical Wall Support (Wood, Concrete, Steel)	28
Single Wall Floor Support	31
Grease Duct Assembly Examples	37
Chimney Assembly Examples	40
Methods Used to Test After Assembly	41
Method 1 - Light Test per IMC 506.3.2.5	41
Method 2 - Smoke Test	41
Method 3 - Pressure Testing per SMACNA's HVAC Air Duct Leakage	41
General Duct Weight	44
Weight – 20 Gauge Duct	44
Weight – 18 Gauge Duct	44

WARRANTY

This ductwork and chimney system is warranted to be free from defects in material and workmanship, under normal use and service, for a period of 20-years from the date of shipment. This warranty shall not apply if:

1. The equipment is not installed by a qualified installer per this installation guide; this guide should be kept with the equipment once installation is complete.
2. The equipment is not installed in accordance with Federal, State, and Local codes and regulations.
3. The equipment design or sizing is not approved per MANUFACTURER'S specifications.
4. The equipment is misused, neglected, or not maintained per the MANUFACTURER'S maintenance instructions.
5. The equipment is exposed to elevated temperatures due to a fire originating in the building, hood, fan, duct, chimney, or kitchen appliances.
6. The equipment is not operated within its published capacity.
7. The equipment is operated, tested, or stored in the presence of chlorines, solvents, refrigerant vapors, caustic substances, halogenated compounds, or other conditions that could cause condensation of corrosive materials within or on the system.
8. The equipment is substituted or connected with parts not manufactured per Original Equipment Manufacturer.
9. The invoice is not paid within the terms of the sales agreement.

The MANUFACTURER shall not be liable for incidental and consequential losses and damages potentially attributable to malfunctioning equipment. Should any part of the equipment prove to be defective in material or workmanship within the 20-year warranty period, upon examination by the MANUFACTURER, such parts will be repaired or replaced by the MANUFACTURER at no charge. The BUYER shall pay all labor costs incurred in connection with such repair or replacement. Equipment shall not be returned without MANUFACTURER'S prior authorization, and all returned equipment shall be shipped by the BUYER, freight prepaid to a destination determined by the MANUFACTURER.

LISTINGS

This Grease Duct has been tested and is listed to UL1978, CAN/ULC-S662, diameters 4" through 36".

Model DW is used for grease duct applications when installed in accordance with these instructions and National Fire Protection Association "NFPA 96"; Standard for Ventilation Control and Fire Protection of Commercial Cooking Operations.

Factory Built Chimney Model DW has been tested and is listed to UL103, diameters 4" through 16". Testing has been extended to recognize ULC/ORD-C959-1993, unenclosed installation and is for commercial use only. Factory Built Chimney Model DW has been tested and is listed for installations in positive pressure applications where the chimney is subject to positive pressure rather than negative or neutral pressures.

The chimney system is rated for use at maximum 60 inch water column internal pressure when used in Positive Pressure Applications, diameters 4" through 16".

Factory Built Chimney Model DW has been tested and is listed to UL2561, diameters 4" through 16". Testing has been extended to recognize ULC/ORD-C959-1993, unenclosed installation and is for commercial use only.

Factory Built Chimney Model DW is intended for installation within commercial/industrial applications and is not intended for use in family dwellings. When installed in accordance with these instructions and National Fire Protection Association "NFPA 211"; Standard for Chimneys.

APPLICATION

Grease Duct

The listed grease duct is suitable for use in commercial cooking installations for the removal of smoke and grease-laden vapors. The grease duct system includes all components for a complete exhaust system from the hood to the exhaust fan inlet.

NOTE: For caustic environments, duct systems will be constructed of 444 stainless steel (SS) parts. The duct and joint connections (V bands) will be constructed of 444 SS and supplied with 316 SS hardware.

Grease duct installations require provisions for cleaning the interior of the duct. NFPA 96 clean-out requirements are as follows:

1. A clean-out must be provided at each change of direction except where the entire length of duct can be inspected and cleaned from either the hood or the discharge end.
2. On horizontal duct runs, at least one 20" diameter opening must be provided. Where the opening is smaller than 20" diameter, openings large enough to permit cleaning must be provided at intervals of no more than 12'.
3. Openings must be at the side or the top, whichever is more accessible. When the opening is on the side of the duct, the lower edge of the opening must be at least 1-1/2" above the bottom of the duct. For the listed grease duct, this is accomplished by the use of the grease manifold tee and clean-out cap.
4. On vertical duct runs where personnel entry is possible, access must be from the top of the riser. Where entry is not possible, access must be provided at each floor.

NOTE: Access requirements are subject to change per local code. Local authorities should be consulted for exact requirements. Grease duct may be connected only to hoods in a single fire zone on one floor. Do not connect grease ducts to any other part of the building ventilation or exhaust system.

When grease duct is installed following these installation instructions and the joints are sealed properly with the recommended sealant, the system will contain a grease fire within the duct. A grease fire can burn at extremely high temperatures. This system should be dismantled and inspected after any exposure to a grease fire. Any section that is distorted or discolored should be replaced. All joints in the system should be examined. Because the sealant expands to assure a positive seal in the case of a fire, any sealant that has been exposed to high temperatures must be replaced. This will ensure that the system maintains its integrity against fire conditions in the future. The manufacturer of this grease duct cannot be responsible for grease duct systems that are not properly maintained or have been subjected to one or more grease fires.

Grease duct systems size and capacity information may be obtained from the "ASHRAE Handbook – Fundamentals" or from the "Air Pollution Engineering Manual" of the "US Environmental Protection Agency." Refer to the grease duct systems catalog for descriptions and dimensional data of parts.

Chimneys

NOTE: For caustic environments, chimney systems will be constructed of 444 stainless steel (SS) parts. The chimney and joint connections (V bands) will be constructed of 444 SS and supplied with 316 SS hardware.

Factory Built Chimney Model DW is listed for continuous internal temperatures of 1000°F US & 600°F Canada. Factory Built Chimney Model DW is listed for continuous internal temperatures of 1400°F US & Canada. This system is ideally suited for commercial and industrial application for the removal of smoke and heat, and is rated for use at a maximum 60 inch water column internal pressure when used in positive pressure applications. Single wall chimney systems are available in diameters 4" through 16". Chimney system size and capacity information may be obtained from the *ASHRAE Handbook – Fundamentals* or from the *Air Pollution Engineering Manual* of the US Environmental Protection Agency.

NOTE: Model DW Chimney Systems used for positive pressure applications must be sealed with the recommended sealant listed in this manual. NO SEALANT SUBSTITUTES MAY BE USED. Model DW Chimney Systems used for neutral or negative pressure applications do not require joints to be sealed.

When wood is burned slowly, it produces tar and other organic vapors which combine with expelled moisture to form creosote. The creosote vapors condense in a relatively cool chimney flue of a slow burning fire. As a result, creosote residue accumulates on the chimney lining. When ignited this creosote makes an extremely hot fire.

Chimney installations require provisions for cleaning the interior of the chimney. Creosote and soot formations need to be removed. The chimney should be inspected once every two months during the heating season to determine if creosote or soot buildup has occurred. If creosote or soot has accumulated, it should be removed to reduce the risk of fire. Clean-out requirements are as follows:

1. A clean-out must be provided at each change of direction, except where the entire length of chimney can be inspected and cleaned from either the equipment or the chimney cap.
2. Openings must be at the side or the top, whichever is more accessible.
3. The chimney inspection should be done every two months during the heating season.
4. If creosote or soot has accumulated it should be removed to reduce the risk of fire.
5. Insert the chimney cleaning brush and brush in a downward motion, be sure to scrub all sides of the chimney thoroughly and remove all debris.
6. Contact local building or fire officials about restrictions and inspections in your area.

NOTE: Model DW Factory Built Chimney Systems are intended for commercial and industrial applications. This system is not intended for family dwellings. Chimney Systems should be sized in accordance with the appliance manufacturer's instructions.

When the chimney system is installed in accordance with these installation instructions and the joints are sealed properly with the recommended sealant, the system will contain a fire within the chimney. A fire can burn at extremely high temperatures. The system should be dismantled and inspected after any exposure to a fire. Any section that is distorted or discolored should be replaced. All joints in the system should be examined.

The sealant expands to ensure a positive seal in the case of a fire, and any sealant that has been exposed to high temperature must be replaced. This will ensure that the system maintains its integrity against fire conditions in the future. The manufacturer of this chimney system cannot be responsible for chimney systems that are not properly maintained or have been subjected to one or more fire conditions.

MECHANICAL

Joint Sealant

Proper joint assembly is essential for safe installation. Follow these instructions exactly as written. Check severeness of joints upon completion of assembly.

The joint sealant used to seal all joint assemblies is 3M Fire Barrier 2000+ Silicone Sealant. This sealant is a ready-to-use, gun-grade, one-component silicone elastomer that cures upon exposure to atmospheric humidity to form a flexible seal. 3M Fire Barrier 2000+ Silicone Sealant, when installed properly, will control the spread of a fire before, during, and after exposure to open flames. It will stop the spread of noxious gas, smoke, and water, and maintain the integrity of fire-rated assemblies and construction. All grease ducts must be liquid-tight per NFPA 96. Chimney used in positive pressure applications must be liquid-tight per UL103 listing. Chimney used in neutral or negative pressure applications does not require joints to be sealed with the 3M Fire Barrier 2000+ Silicone Sealant per the listing report it is recommended for commercial cooking appliances where grease is present. **Table 1** provides tube usage per duct diameter.

NO SEALANT SUBSTITUTES MAY BE USED.

Sealant Features

1. Superior adhesion. Applied with a standard caulk gun.
2. Class 25 sealant, per ASTM C920. Capable of withstanding 2000°F + temperatures.
3. Re-enterable/repairable. Provides up to 4-hours fire-rating.
4. Cures upon exposure to atmospheric humidity. Working time 30 minutes. Full cure time: 14 to 21 days.
5. The duct/chimney can be placed in operation 7 days after installation, before full cure.

Table 1 - 3M Fire Barrier 2000 Plus Usage Chart

Diameter	Duct Perimeter Feet	Average Feet Per Tube	Number of Joints Per Tube
5"	1.43	30	10.5
6"	1.70	30	9
7"	1.96	30	7.5
8"	2.16	30	7
10"	2.68	30	6
12"	3.21	30	5
14"	3.73	30	4
16"	4.25	30	3.5
18"	4.78	30	3
20"	5.30	30	3
22"	5.83	30	2.5
24"	6.35	30	2.5
26"	6.93	30	2
28"	7.46	30	1.5
30"	7.98	30	1.5
32"	8.39	30	1.5
34"	8.91	30	1
36"	9.55	30	1

Grease Duct & Chimney Joint Assembly

All grease ducts are to be liquid tight per NFPA 96. Chimney used in positive pressure applications must be liquid tight per UL103 listing. When a chimney system is used in a positive pressure application, it must be fitted with an internal joint collar and sealed as shown in **Figure 1** (positive pressure only). Positive pressure applications must be liquid tight per UL103 Positive Pressure Testing. When a chimney system is used in a negative or neutral pressure application, it does not need to be sealed per the listing report; although, sealing the system is recommended for commercial cooking appliances where grease is present.

1. Apply a continuous bead of 3M Fire Barrier 2000 + Silicone Sealant around the flange to be joined. The bead should be 1/4" thick and continuous. Refer to "**Joint Sealant**" on page 8 for sealant details. For neutral and negative chimney or grease duct applications, proceed to step 4.
2. For positive pressure chimney applications, apply 1/4" wide continuous bead of 3M Fire Barrier 2000 + Silicone around the formed bead of the internal joint collar. Push the internal collar down into the chimney section assembly.
3. For positive pressure chimney applications: The internal joint collar should be pushed down into the chimney section until the collar bead sits on the chimney flange.
4. Join the two flanged ends of the duct/chimney section together.
5. Fill the V-clamp with 3M Fire Barrier 2000 + Silicone Sealant. The bead should be inside the "V".
6. Install the V-clamp around the duct/chimney sections. Both duct/chimney flanges should be inside the "V".
7. For horizontal runs, the V-clamp hardware should be located on the top side of the duct/chimney and orientated between the 3 and 9 o'clock position.
8. NEVER install the V-clamp with the hardware orientated on the bottom side of the duct/chimney on horizontal runs.
9. Secure the V-clamp around the duct/chimney by tightening the 1/4"-20 hardware between **40 - 60 in-lbs**. See **Figure 1** for details. Smooth out any excess sealant from the inside of the duct/chimney surface.

Figure 1 - Joint Assembly

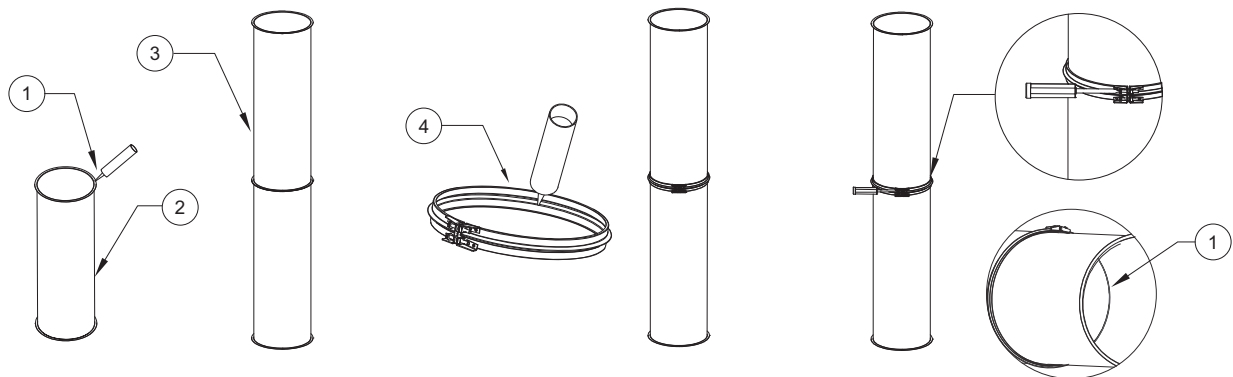

1. 3M Fire Barrier 2000 + Silicone Sealant
2. Duct/Chimney Section

3. Connecting Duct/Chimney Section
4. V-band

IMPORTANT: THE HARDWARE USED TO ASSEMBLE THIS DUCTWORK/CHIMNEYSECTION IS SPECIFICALLY DESIGNED FOR THIS APPLICATION. NO SUBSTITUTE HARDWARE IS ALLOWED. ALL REPLACEMENT HARDWARE MUST BE PURCHASED FROM THE FACTORY.

Single Wall Collar and Adjustable Grease Duct/Chimney Connections

The collar and the adjustable duct/chimney length have two major functions: One function is to make up odd lengths of duct as needed in short runs, as in termination of the duct/chimney at the exhaust fan. Another function is to serve as an expansion joint for thermal expansion in larger duct/chimney runs. Refer to **Figure 2** for adjustable duct assembly details.

When used in systems of any orientation, it can perform both functions simultaneously. The adjustable duct section is overlapped to allow grease to drain back to the hood in both vertical and horizontal installations, see **Figure 28** through **Figure 30**. The adjustable duct/chimney is flanged at one end only. The collar is constructed of the same material as the duct/chimney and is also designed with a 1/2" flange that is connected to the standard duct section using the "**Grease Duct & Chimney Joint Assembly**" on **page 9** method. Collars are also sealed using high-temperature silicone that compresses around the adjustable duct/chimney when the collar hardware is tightened. The collar is designed to securely hold the adjustable duct/chimney while allowing for thermal expansion. If the protruding section interferes with mating parts in the duct/chimney run, you will need to field cut the adjustable section. Verify the minimum overlap is set correctly, refer to **Table 2**.

NOTE: When installing duct/chimney sections, verify the directional label is in the correct direction of airflow. Exception: When grease is draining in a downward slope, the arrow should be opposite of airflow.

Figure 2 - Adjustable Grease Duct/Chimney Overlap

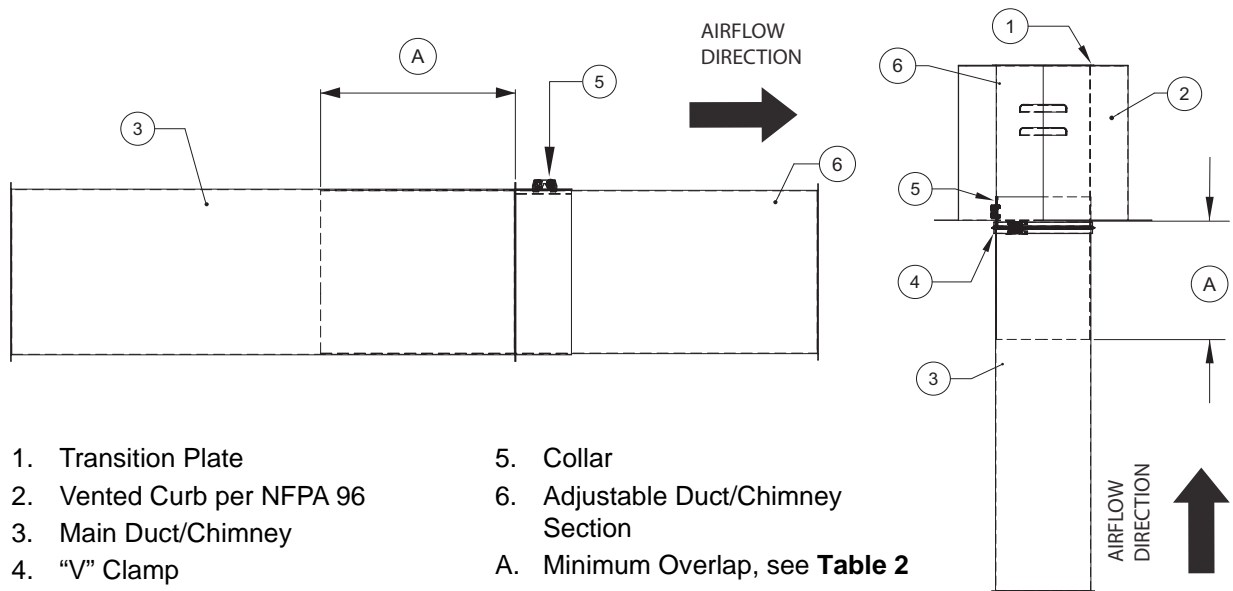

Table 2 - Minimum Overlap

Grease Duct Diameter	Minimum Overlap for Adjustable Duct
5", 6", 7", 8"	4"
10"	5"
12", 14", 16", 18", 20", 22", 24", 26", 28", 30", 32", 34", 36"	6"
Chimney Diameter	Minimum Overlap for Adjustable Chimney
5", 6", 7", 8"	4"
10"	5"
12", 14", 16"	6"

Single Wall Collar and Adjustable Grease Duct/Chimney Vertical Installation

When the adjustable length duct/chimney and collar are installed in the vertical position between two fixed points, such as the beginning support and the ending support, it should be installed just below the higher support. To ensure proper axial alignment, wall guide support assemblies must be installed below the duct/chimney joint immediately below the adjustable duct/chimney. This combination of parts will force the sliding inner and outer parts of the adjustable duct/chimney to overcome collar friction, allowing movement along the axis of the duct/chimney. This relieves expansion stresses, which would otherwise develop between the fixed points of the heated vertical duct/chimney. Refer to **Figure 3** for assembly details.

1. Slide the adjustable collar over the adjustable duct/chimney. Flanges should be opposite of each other.
2. Slide the adjustable duct/chimney into the standard duct/chimney to the point that the collar flange and the standard duct/chimney flange meet.
3. The adjustable collar and standard duct/chimney are joined and sealed using the “**Grease Duct & Chimney Joint Assembly**” on **page 9** method.
4. Slide the adjustable duct into the standard duct to the desired length. If the protruding section interferes with mating parts in the duct/chimney run, you will need to cut the adjustable duct/chimney section that is interfering with mating parts. Minimum overlap dimensions are specific to the duct/chimney diameter. Refer to **Table 2 on page 10** for proper overlap specifications.
5. Once the desired overlap has been set, all mating parts must be sealed using 3M Fire Barrier 2000 Plus.
6. Install V-clamp. Tighten the 1/4”-20 hardware on the V-clamp and the outside of the adjustable collar between **40 - 60 in-lbs**.
7. Inspect the connection for gaps in silicone.

Figure 3 - Collar and Adjustable Grease Duct/Chimney Installation

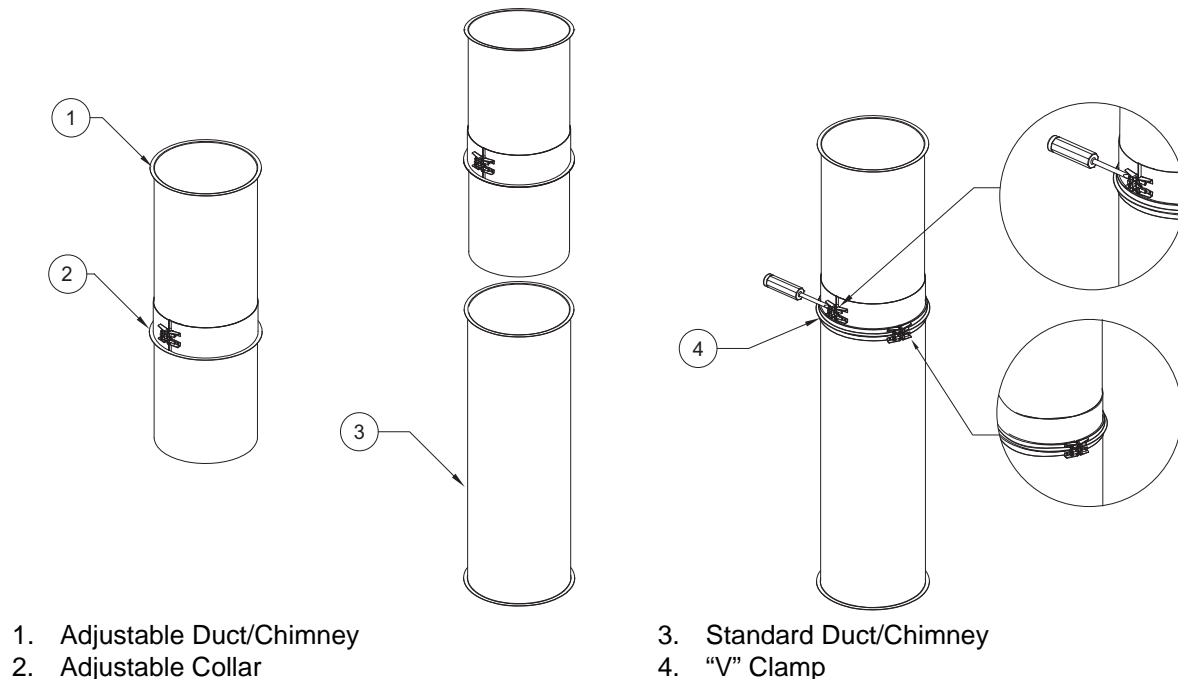

1. Adjustable Duct/Chimney
2. Adjustable Collar

3. Standard Duct/Chimney
4. "V" Clamp

Single Wall Offset Distance

Refer to page 12 through page 14 for single wall offset details.

Table 3 - Offset Center Line Distance 15 Degree Elbows

Diameter	Flange Diameter	Part Number	HT 1	CL 1
5"	6"	DW0515ASY	19"	2-1/2"
6"	7"	DW0615ASY	19-1/4"	2-1/2"
7"	8"	DW0715ASY	19-1/2"	2-1/2"
8"	9"	DW0815ASY	19-3/4"	2-1/2"
10"	11"	DW1015ASY	20-3/8"	2-5/8"
12"	13"	DW1215ASY	20-7/8"	2-3/4"
14"	15"	DW1415ASY	21-3/8"	2-7/8"
16"	17"	DW1615ASY	21-7/8"	2-7/8"
18"	19"	DW1815ASY	22-3/8"	3"
20"	21"	DW2015ASY	22-7/8"	3"
22"	23"	DW2215ASY	23-3/8"	3-1/8"
24"	25"	DW2415ASY	23-7/8"	3-1/8"
26"	27"	DW2615ASY	24-1/2"	3-1/4"
28"	29"	DW2815ASY	25"	3-1/4"
30"	31"	DW3015ASY	25-1/2"	3-3/8"
32"	33"	DW3215ASY	26"	3-1/2"
34"	35"	DW3415ASY	26-1/2"	3-1/2"
36"	37"	DW3615ASY	27-1/8"	3-1/2"

Figure 4 - 15 Degree Offset Details

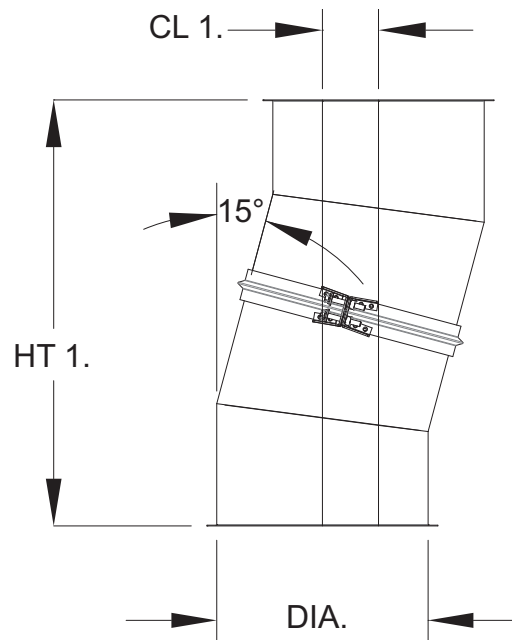

Table 4 - Offset Center Line Distance 30 Degree Elbows

Diameter	Flange Diameter	Part Number	HT 1	CL 1
5"	6"	DW0530ASY	19-3/8"	5-1/8"
6"	7"	DW0630ASY	19-7/8"	5-3/8"
7"	8"	DW0730ASY	20-3/8"	5-1/2"
8"	9"	DW0830ASY	20-7/8"	5-1/2"
10"	11"	DW1030ASY	21-7/8"	5-7/8"
12"	13"	DW1230ASY	22-7/8"	6-1/8"
14"	15"	DW1430ASY	23-7/8"	6-3/8"
16"	17"	DW1630ASY	24-7/8"	6-5/8"
18"	19"	DW1830ASY	25-7/8"	7"
20"	21"	DW2030ASY	26-7/8"	7-1/8"
22"	23"	DW2230ASY	27-3/8"	7-3/8"
24"	25"	DW2430ASY	28-7/8"	7-3/4"
26"	27"	DW2630ASY	29-7/8"	8"
28"	29"	DW2830ASY	30-7/8"	8-1/4"
30"	31"	DW3030ASY	31-7/8"	8-1/2"
32"	33"	DW3230ASY	32-7/8"	8-3/4"
34"	35"	DW3430ASY	33-7/8"	9"
36"	37"	DW3630ASY	34-7/8"	9-3/8"

Figure 5 - 30 Degree Offset Details

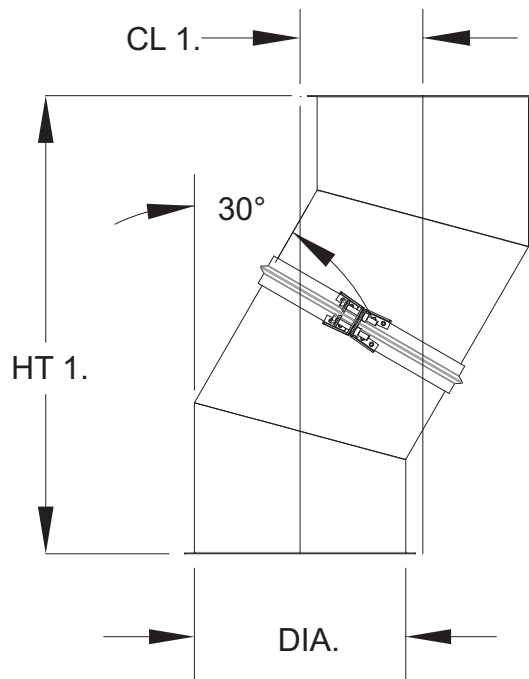
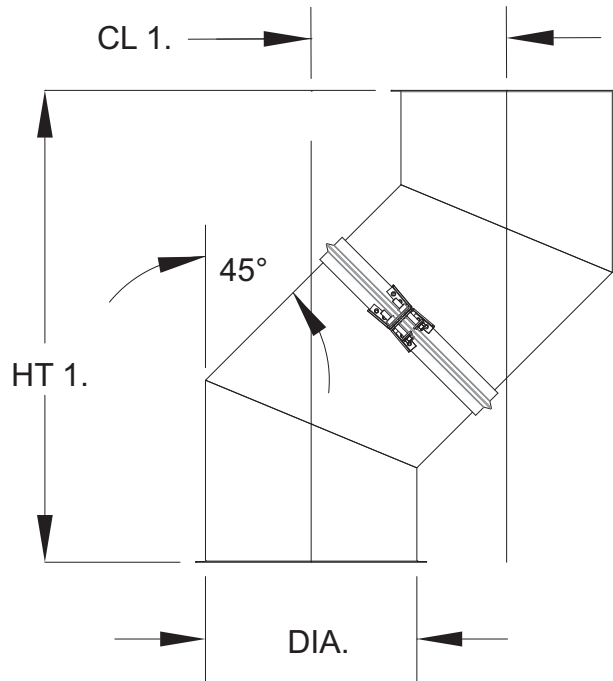

Table 5 - Offset Center Line Distance 45 Degree Elbows

Diameter	Flange Diameter	Part Number	HT 1	CL 1
5"	6"	DW0545ASY	18-7/8"	7-7/8"
6"	7"	DW0645ASY	19-5/8"	8-1/8"
7"	8"	DW0745ASY	20-3/8"	8-1/2"
8"	9"	DW0845ASY	21"	8-3/4"
10"	11"	DW1045ASY	22-1/2"	9-3/8"
12"	13"	DW1245ASY	23-7/8"	9-7/8"
14"	15"	DW1445ASY	25-3/8"	10-1/2"
16"	17"	DW1645ASY	26-3/4"	11"
18"	19"	DW1845ASY	28-1/8"	11-5/8"
20"	21"	DW2045ASY	29-1/2"	12-1/4"
22"	23"	DW2245ASY	30"	12-7/8"
24"	25"	DW2445ASY	32-3/8"	13-3/8"
26"	27"	DW2645ASY	33-7/8"	14"
28"	29"	DW2845ASY	35-1/4"	14-1/4"
30"	31"	DW3045ASY	36-5/8"	15-1/4"
32"	33"	DW3245ASY	38"	15-3/4"
34"	35"	DW3445ASY	39-1/2"	16-3/8"
36"	37"	DW3645ASY	40-7/8"	17"

Figure 6 - 45 Degree Offset Details



Clearances - Grease Duct

This grease duct is primarily intended for use in non-combustible surroundings when installed in a room where enclosure is not required. Grease duct may be located at clearance to combustibles, as shown in **Table 6**. Grease duct may be located in a corner formed by two combustible walls, provided the minimum clearance is maintained.

In all buildings more than one story in height and in buildings where the roof-ceiling assembly is required to have a fire-resistance rating, the duct must be enclosed in a continuous enclosure from the lowest fire-rated ceiling or floor above the hood, through any concealed spaces, to or through the roof to maintain the integrity of the fire separations required by the applicable building code provisions. If the building is less than 4 stories in height, the enclosure shall have a fire-resistance rating of not less than 1 hour. If the building is 4 stories or more in height, the enclosure shall have a fire-resistance rating of not less than 2 hours. The clearance between the outside of the duct and the inside of the rated enclosure must be a minimum of 6 inches or required by code.

Combustible roofs or roof-ceiling assemblies may be penetrated using the vertical support assembly when distance to combustible surfaces is maintained.

Table 6 - Grease Duct Clearance to Combustibles

Diameter	UL1978 Clearance to Combustibles	UL1978 Clearance to Limited Combustibles	Clearance to Non-Combustibles
5", 6", 7", 8", 10", 12", 14", 16", 18", 20", 22", 24", 26", 28", 30", 32", 34", 36"	18"	3"	0"

The information in **Table 6** represents air space, in inches, to surroundings.

Note: Refer to the latest edition of NFPA 96, Chapter 3 Definitions. This explains the definitions of combustible, non-combustible and limited combustible material.

Zero Clearances to Combustibles

This duct is to be used in non-combustible surroundings. Where the duct does not require an enclosure, it must have a minimum clearance to adjacent combustible walls, as shown in **Table 6**. In cases where the ducting extends through any story of a building above the location at the connected appliances, it must be enclosed in the upper stories with walls having a fire-resistance rating of not less than one hour for buildings of two or three stories in height. If the building is four stories or more in height, the enclosure wall shall have a fire-resistance rating of not less than two hours.

Clearances - Chimney

In all buildings more than one story in height and in buildings where the roof/ceiling assembly is required to have a fire resistance rating, the chimney must be enclosed in a continuous enclosure. This enclosure will be from the lowest fire-rated ceiling or floor above the appliance, through any concealed spaces, to or through the roof to maintain the integrity of the fire separations required by the applicable building code provisions.

If the building is less than 4 stories in height, the enclosure shall have a fire resistance rating of not less than 1 hour. If the building is 4 stories or more in height, the enclosure shall have a fire resistance rating of not less than 2 hours. When installed in an open room where an enclosure is not required, double wall chimney may be located at clearance to combustibles in accordance with **Table 7**. All through floor penetrations will contain an insulated section of double wall DW-2R chimney that allows for a reduced clearance.

Table 7 - Chimney Clearances to Combustibles

Diameters	Thimble Assembly Shell Diameter (Thru Penetration)	Thimble Assembly Clearance to Combustibles to Joist)	UL103 Clearance to Combustibles (Chimney to Ceiling/Wall)	UL2561 Clearance to Combustibles (Chimney to Ceiling/Wall)	Clearance to Non-Combustibles	Through Floor Opening
5"	9"	2"	18"	36"	0"	13-1/2"
6"	10"	2"	18"	36"	0"	14-1/2"
7"	11"	2"	18"	36"	0"	15-1/2"
8"	12"	2"	18"	36"	0"	16-1/2"
10"	14"	2"	18"	36"	0"	18-1/2"
12"	16"	2"	18"	36"	0"	20-1/2"
14"	18"	2"	18"	36"	0"	22-1/2"
16"	20"	2"	18"	36"	0"	24-1/2"

The information in **Table 7** represents air space, in inches, to surroundings.

NOTE: Clearance plates are not required for chimney thimble assemblies, a 2" clearance to combustibles will be maintained between the DW-2R shell and combustible surface in the joist area.

NOTE: Table 7 on page 16 shows two different clearances; chimney clearance is from the chimneys outer diameter (OD) to the combustible ceiling/floor. The thimble assembly clearance is from the chimneys shell OD to the combustible joist. It is important that all clearance to combustibles noted in Table 7 and on the UL label are followed.

Figure 7 - Chimney Clearance

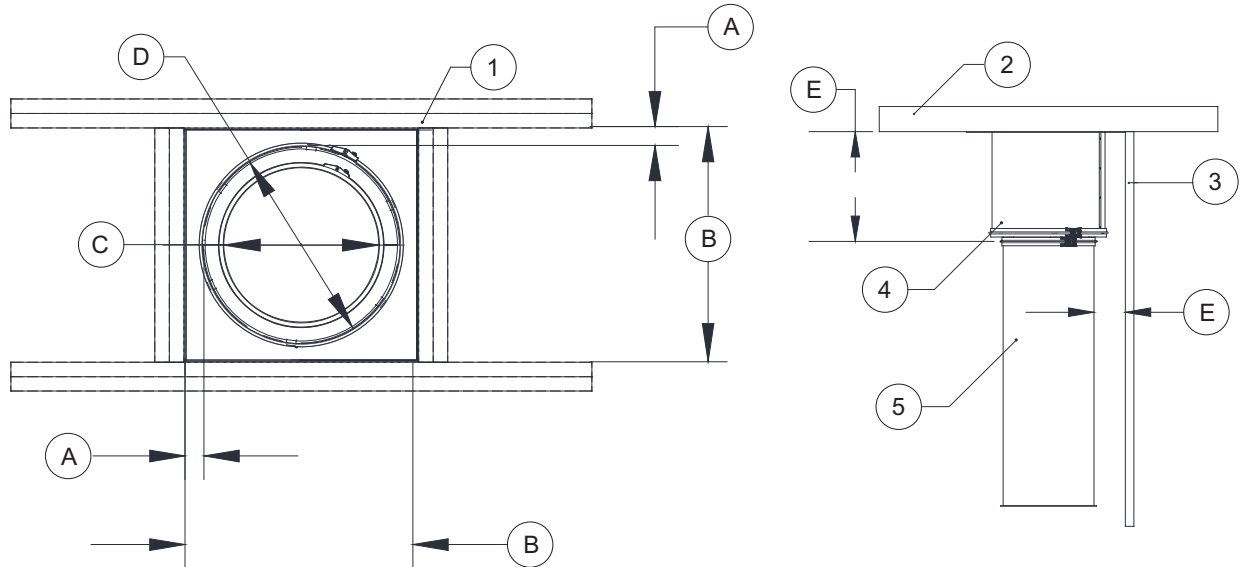

- 1. Combustible Surface
- 2. Ceiling
- 3. Wall
- 4. DW-2R Double Wall Thimble Assembly
- 5. Single Wall Chimney Section

- A. Clearance to Combustibles (Shell to Joist), refer to **Table 7**
- B. Wall/Floor Opening, refer to **Table 7**
- C. Chimney Diameter
- D. DW-2R Shell Outer Diameter (OD)
- E. Clearance to Combustibles (Chimney to Ceiling/Wall), refer to **Table 7**

Single Wall Chimney Supports

Single wall chimney supports, floor, and wall support assemblies are used to support chimney sections that penetrate a floor or wall. Each of these support assemblies consists of a main support, and a set of optional clearance plates. Clearance plates can be used as the main support shown in **Figure 8** or used in conjunction with support assemblies. Clearance plates are designed to maintain the clearance to combustibles while keeping the chimney centered in the floor or wall opening. Clearance plates may be removed if a tighter clearance is desired, refer to **Table 7 on page 16** for measurements and more information.

Figure 8 - Wall Support Assembly

1. Wall
2. Ceiling
3. Single Wall Section
4. Clearance Plates (optional)
- A. Clearance to Combustibles (Ceiling/Wall), refer to **Table 7**
- B. Clearance to Combustibles (Shell to Joist), refer to **Table 7**

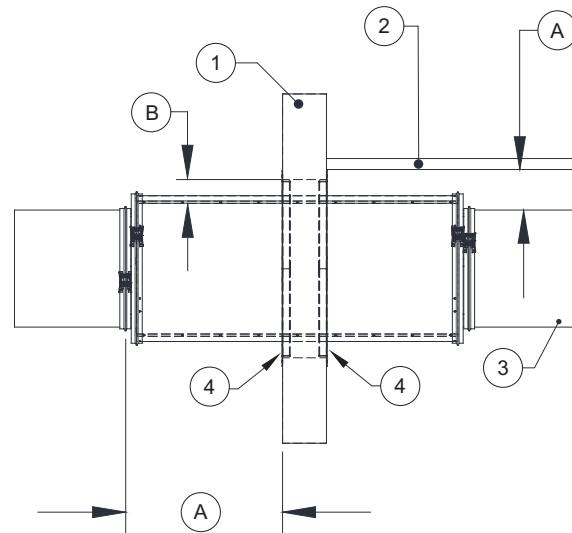
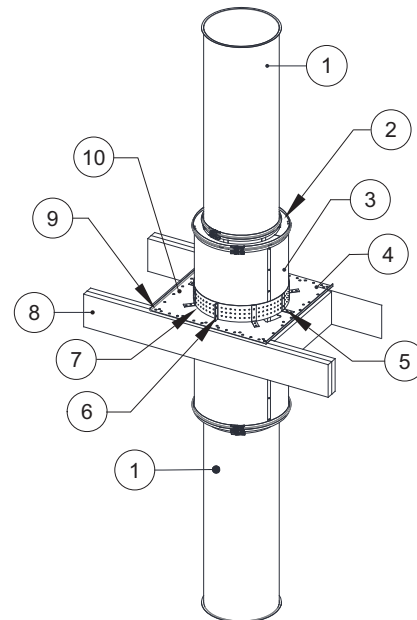

Figure 9 - Floor Support Assembly

1. Single Wall Section
2. End Cap
3. 2R Double Wall Chimney
4. Floor Support Assembly
5. 5/16"-18 x 1-1/2" Self Drilling Screws.
6. 1/4"-20 Whiz Nuts and Bolts.
7. Vertical Support Ring
8. Joist
9. Substrate Hardware, refer to **Table 8 on page 19**
10. Vertical Support Plate



Single Wall Chimney Annular Distance and Clearance

Optional clearance plates are used to maintain clearance to combustibles for 2R listed chimney systems. These clearance plates are not a hanging substitute for through penetration and fire stop plates. Chimney clearance plates are designed to center the chimney in the recommend opening and maintain clearance to combustibles as shown in **Figure 7 on page 17**. Chimney clearance plates consist of two half plates; the plates are designed so they are inserted into the opening. The plates are installed on the bottom side of the floor or on both sides of a wall. Frame or cut the opening in the floor/wall, refer to **Table 7 on page 16**. Insert the chimney into the opening, then insert one half of the clearance plate. Secure the half plate using appropriate hardware for substrate construction, refer to **Table 8**. Insert the second half plate and secure. Once both plates are secure, the chimney will be centered in the opening with a clearance to combustibles. **All through floor and wall penetrations will contain an insulated section of double wall 2R chimney that allows for a reduced clearance.**

WARNING: Clearance (air space) to combustibles must be free from any type of insulation.

Figure 10 - Optional Clearance Plates (Floor Installation Shown)

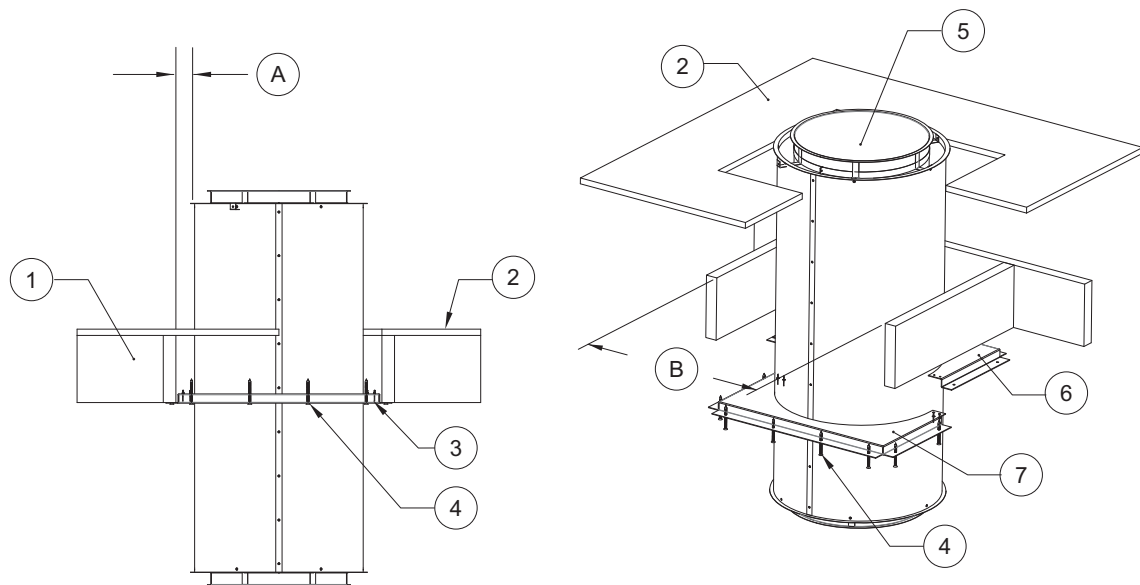

1. Joist
2. Floor
3. Optional Clearance Plates - Shown installed
4. Clearance Plate Hardware
5. Chimney

6. Clearance Plate 1
7. Clearance Plate 2
- A. Clearance to Combustibles (Shell to Joist), refer to **Table 7**
- B. Floor Opening, refer to **Table 7**

Table 8 - Substrate Hardware Table

Decking Material	Hardware	Edge Distance
Wood - Min G.42	3/8" x 2-1/2" Zinc Plated Steel Hex Head Lag Screw with 3/8" Zinc Plated Steel Washer	1-1/2" Minimum
Concrete - 2500 Min PSI	3/8" Diameter - Expansion Anchor Hilti Kwik Bolt TZ with 3/8" Zinc Plated Steel Washer	3" Minimum
Steel - Roof Truss 12 Gauge or 1/8" Thick	1/4"-14 Min. 1/2" Through Drill-Flex Self-Drilling Screws with 1/4" Zinc Plated Steel Washer	3/8" Minimum

Factory and Field (Bolted and Welded) Risers

There are two options for the riser, this is the connection to hood plenum. There may be welded (factory or field) or bolted.

Dimensional data identifying the size and location of the riser must be provided for factory installation. The riser is fully welded to the hood plenum.

When field installed, the riser is shipped loose allowing the installer at the jobsite to decide on the final location of the riser. Field installed risers help when the final location is not known, or adjustments may need to be made due to grease duct/chimney misalignments. Field installed risers may be welded or bolted in place. Refer to **Figure 11** for assembly details.

1. Locate the specific position at which the riser needs to be installed.
2. Use the riser as a guide when marking the hood.

NOTE: Verify the hole location is inside the plenum area before cutting any holes.

3. Use the single-piece riser ring as a template to mark the bolt hole locations. Align the inner circles of the hole in the plenum with the single-piece riser ring. Mark the bolt hole circle. Make sure the bolt hole circle is inside the plenum area before cutting.
4. Use 3M Fire Barrier 2000+ Silicone to seal around the riser hole. Apply sealant to the top and bottom of the hole. Make sure the silicone bead is a minimum of 1/4" thick and is continuous inside and outside of the bolt hole circle.
5. Center the riser over the hole in the plenum and push down. Make sure the riser flange is positively sealed. Make sure the two-piece riser ring on the riser is pushed down into the sealant. Sealant should come through the holes on the ring.
6. Align the single-piece riser ring to the hole on the inside of the plenum and push into the silicone.
7. Align the two-piece riser ring above the hood and bolt the rings together using 1/4"-20 bolts and nuts. **Make sure the tabs are on top.**

NOTE: The bolt head must be installed on the plenum side. This is the bottom side of the hood plenum.

8. Excess silicone should be removed, and the connection should be inspected for gaps and loose hardware.
9. When joining duct to the riser, refer to **"Grease Duct & Chimney Joint Assembly"** on page 9.

Figure 11 - Field Installed Riser (Bolted)

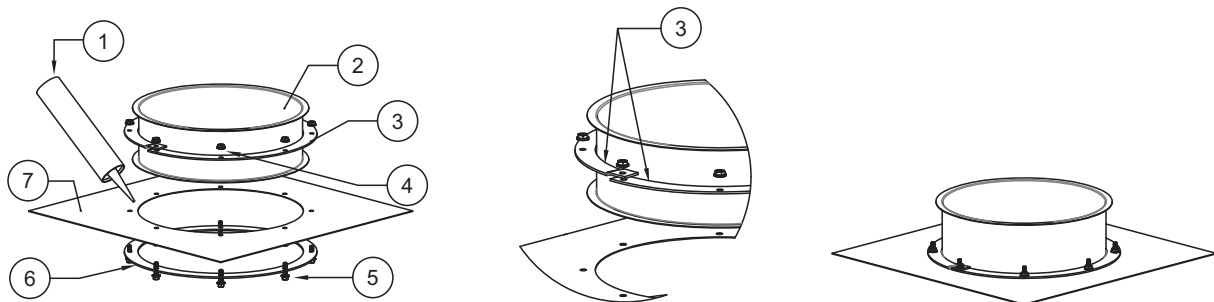

1. 3M Fire Barrier 2000+ Silicone
2. Riser
3. Two-Piece Riser Ring
4. 1/4"-20 Nuts
5. 1/4"-20 Bolts
6. Single-Piece Riser Ring
7. Top of Hood

Duct/Chimney Drains

Drains (**Figure 12**) are used to provide a point at which low points in the duct/chimney system can be drained. Condensation and low lying water left-over from duct cleaning can be drained easily with the installation of the ball valve drain. Drains are designed to aid in cleaning and can be used to drain accumulation into an approved collection reservoir. When an access door cannot be fitted directly to a tee/drain, the mating part should be a tee with an access door. Adapters and/or other components should be used to create a low point in the system, not less than 1". Drains can be hard piped to an approved collection reservoir, remove the cap and connect to the 1-1/2" NPT threads.

Figure 12 - Drain

1. Tee
2. Adapter
3. Drain

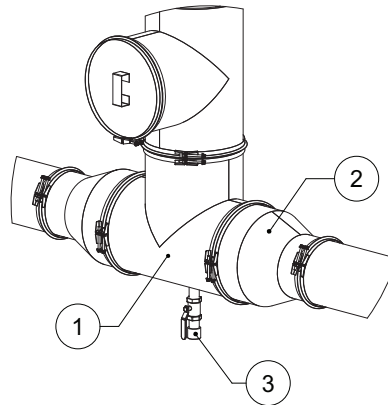

Chimney Drain Trap Loop

A trap loop must be formed into the drain hose. The trap loop diameter must be at least four times the appliance's rated stack pressure in inches of water column (w.c.) or 3 inches, whichever is greater. Refer to **Figure 13** callout (A).

Route drain hose to drain system to dispose of condensate according to local code.

Do not install a condensate drain on the exterior of the building in cold climate areas. This may result in dangerous icy conditions on surfaces near the drain and may cause damage to the chimney system and/or the exterior of the building.

Figure 13 - Chimney Drain Details

1. Appliance Adapter
 2. Vertical Tee Drain or Drain Fitting
 3. Drain
 4. Locknut (by others)
 5. Hose Clamp (by others)
 6. Cable Tie (by others)
 7. Pipe (by others)
- A. Trap Loop Diameter =
Must be at least four times the
appliance's rated stack pressure in
inches of water column (w.c.) or 3
inches, whichever is greater.

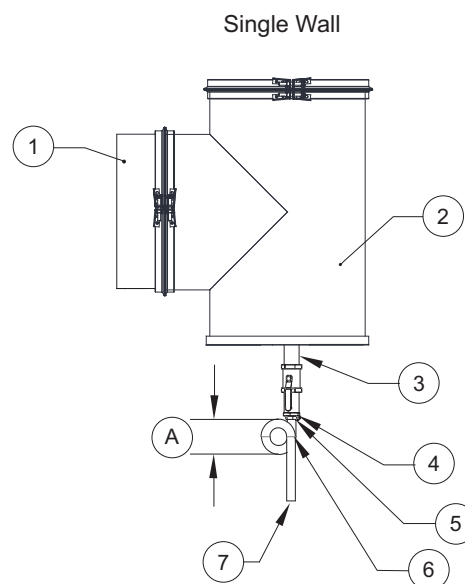

Grease Manifold Tee

The grease manifold tee is used to provide access for clean-out to comply with NFPA 96 requirements. It is equipped with an internal blank that acts as a grease dam and gasket. The access port is then closed with a clean-out cap or tee cap. The location of the access port in the tee is dependent on the orientation of the tee in the final installation. Access port locations are shown in **Figure 14**. Access ports are never located where grease can build up and fall out once the clean-out cap is removed.

Figure 14 - Tee Position

1. Position 1
2. Position 2
3. Position 3
4. Position 4 - Access door removed for clarity.
5. Incorrect Position

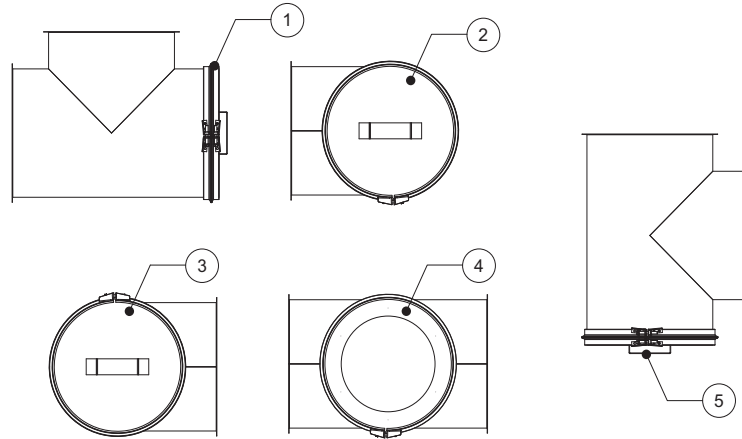

Access Door (Tee Cap) Assembly

Access doors (tee caps) are available 5" to 36" (**Figure 15**). They work in conjunction with the manifold tee, as shown on "**Chimney Drain Trap Loop**" on page 21. The tee joint connection is the same as the joint assembly method shown in "**Grease Duct & Chimney Joint Assembly**" on page 9; however, the installation of the access door is slightly different. Read the following instructions very carefully. Consult NFPA 96, Chapter 7, Section 7.3.1 "*Openings shall be provided at the sides or at the top of the duct, whichever is more accessible, and at change of directions.*"

The Manufacturer will accept the grease duct's installation in a vertical chaseway without cleanouts along the enclosed vertical section as specified in NFPA 96, Chapter 7 - Exhaust Systems, 7.3.3 – "Openings shall not be required in portions of the grease duct/chimney accessible from the duct entry or discharge." The duct run must be readily accessible from the top and bottom of the run, and it is acceptable to the Authority Having Jurisdiction (AHJ).

1. Select the location and the position of the access door.
2. All tee joints will be connected, as shown in "**Grease Duct & Chimney Joint Assembly**" on page 9, except for the access door.
3. Apply the proper sealant to the flange of the tee that will be used for an access door to the duct/chimney system.
4. Apply a 1/4" continuous bead around the tee flange.
5. Center the inside blank over the opening of the tee and apply pressure. Push the inside blank down onto the tee flange sealant to secure the inside blank to the tee flange.
6. Apply enough pressure to create a positive bond between the tee flange and the inside blank. Remove excess sealant after making parts concentric (centered).
7. Apply a 1/4" continuous bead around the inside blank 1" from the outside edge.
8. Center the listed gasket over the inside blank. Push the gasket down into the sealant to secure the gasket to the inside blank.
9. The sealant will begin to cure upon exposure to atmospheric humidity. It will form a flexible seal.
10. Once the sealant is dry, attach the access door using a V-clamp. Verify flanges are in the "V" before tightening 1/4"-20 hardware. Tighten between **40 - 60 in-lbs.**

Figure 15 - Access Door Assembly

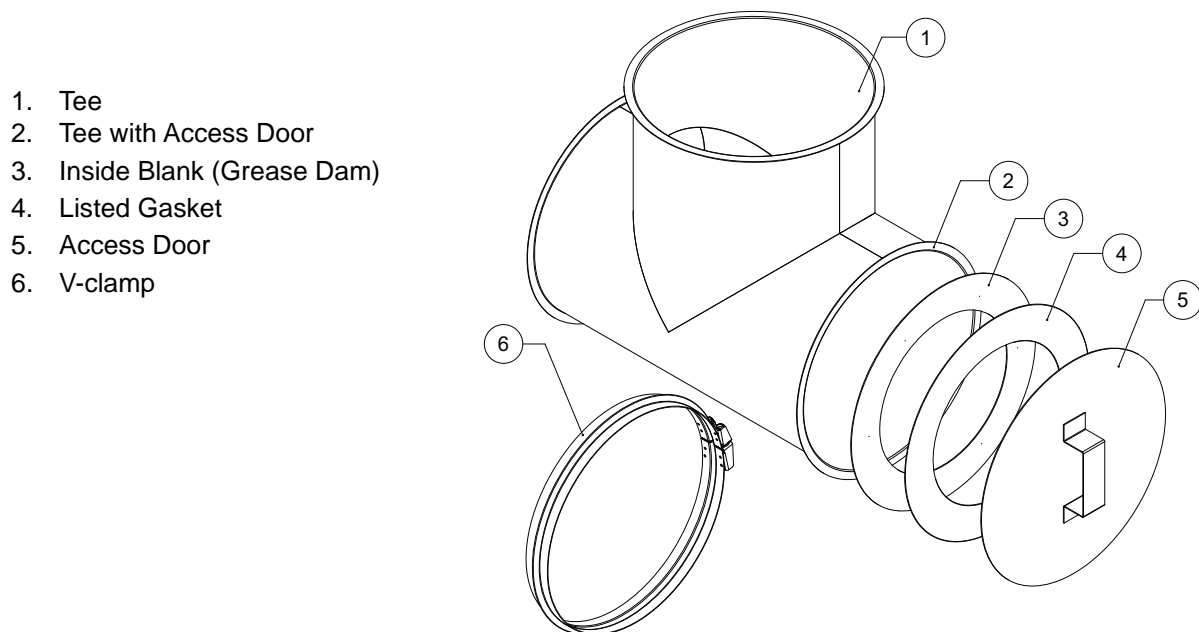

1. Tee
2. Tee with Access Door
3. Inside Blank (Grease Dam)
4. Listed Gasket
5. Access Door
6. V-clamp

Transition Plate

The transition plate is designed to connect to a roof curb (**Figure 16**). The duct section is welded to the underside of the plate. The plate is formed to provide a slope to allow grease deposits to flow back towards the duct. When connected the plate mounts on top of the fan curb, which supports the fan housing. The plate may be positioned off-center within the curb provided that the minimum distance to combustibles is maintained. In the event that the plate is positioned off-center, trim off excess plate material to allow for fan placement. Secure the plate to the curb using a minimum of three fasteners per side. A suitably sized fastener provided by others is used. The transition plate can be used to maintain distance to combustibles and also for vertical support.

Figure 16 - Transition Plate

1. Exhaust Fan
2. Transition Plate, secured to curb by others
3. Vented Curb
4. Adjustable Duct
5. Sealant - Apply sealant between the transition plate and curb.

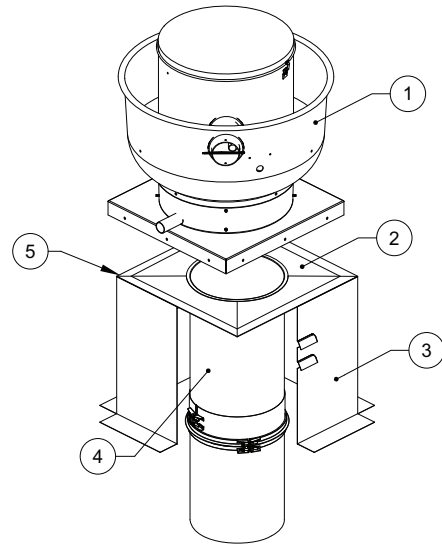

Prevention of Grease Accumulation in Horizontal Grease Duct

Duct systems serving Type 1 hoods shall be constructed and installed so that grease cannot collect in any portion of the duct system. The duct system shall slope not less than 1/16" per linear foot towards the hood or toward an approved grease collection reservoir. Where horizontal ducts exceed 75 feet in length, the slope shall not be less than 3/16" per linear foot. Offset collars have been designed to meet the above specification. The collar is used in conjunction with other accessories such as tees and elbows to maintain the above listed slope in horizontal duct runs. The V-clamp hardware should be located on the top side of the duct and be orientated between the 3 and 9 o'clock position on the duct. Never install the V-clamp with the hardware orientated on the bottom side of the duct on horizontal runs.

Chimney Transition Plate

The transition plate is designed to connect to a roof curb. The chimney section is welded to the underside of the plate. When connected, the plate mounts on top of the curb that supports the chimney cap. The plate may be positioned off-center within the curb provided that the minimum distance to combustibles is maintained. In the event that the plate is positioned off-center, trim off excess plate material to allow for chimney cap placement. Secure the plate to the curb using a minimum of three fasteners per side. A suitably sized fastener provided by others is used. The plate can be used to maintain distance to combustibles and also for vertical support. A ceramic gasket is used to seal the adapter plate to the underside of the chimney cap. A maximum of 24' can be supported by the curb and transition plate combination. Refer to **Table 10 on page 27** for vertical support spacing.

WARNING: NO INSULATION SHALL BE PLACED WITHIN THE REQUIRED CLEARANCE SPACE.

Alignment and Bracing of Grease Duct/Chimney

Grease duct/chimney has the characteristics of a continuous stainless steel pipe, and it will expand and contract along its entire length with changes in its temperature. For this reason, conventional methods of attaching guides and braces to the outer wall of the grease duct cannot be used. Correctly installed support rings, saddles, and wall guide assemblies will serve to keep the duct/chimney aligned, provide for adequate resistance to lateral loads and allow the free axial expansion and contraction movement. A simplified rule for duct expansion is that the axial growth will be approximately 1 inch per 100 feet of pipe length for each 100 degrees Fahrenheit the exhaust vapor temperature is above the surrounding air temperature.

Figure 17 - Chimney Bracing Shown

1. Chimney Cap
2. V-band
3. Chimney Section
4. Transition Plate
5. Floor
6. Double Wall Thimble Assembly

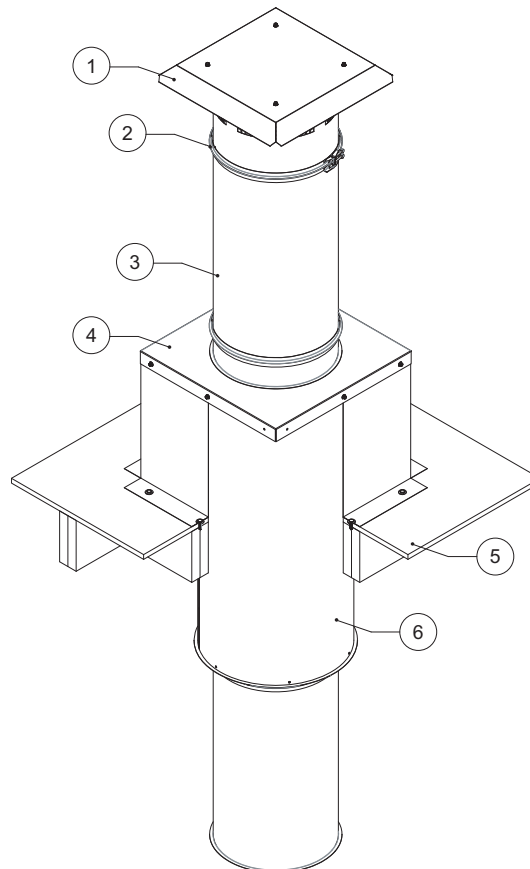

Horizontal Support and Support Spacing

IMPORTANT: HORIZONTAL SUPPORTS SHOWN IN THIS MANUAL ARE RECOMMENDED. SUPPORTS BY OTHERS MUST BE APPROVED BY THE MANUFACTURER AND AHJ. SUPPORT SPACING MUST BE AS STATED IN THIS MANUAL.

Horizontal grease duct/chimney runs are supported using either 2" x 2" x 1/8" angle or B12 Unistrut (**Figure 18**). Horizontal support spacing is shown in **Table 9**. When cutting the angle or Unistrut to length, there must be a minimum of 2" on either side of the duct/chimney. The 1/2" threaded rod suspending the angle or Unistrut must not rub against the duct/chimney. Once the angle has been cut to length, it is suspended using 1/2" threaded rod (minimum). Appropriate sized holes are drilled/punched at either end of the angle. The 1/2" threaded rod is secured to the angle or Unistrut using appropriate sized grade 5 hardware. Washers are used on the top and bottom before installing nuts. Double nuts are used to make sure bottom nuts do not come loose.

Table 9 - Horizontal Support Spacing

Grease Duct Diameter (Inches)	Horizontal Support Spacing (Feet)
5", 6", 7", 8", 10", 12", 14", 16", 18", 20", 22", 24", 26", 28", 30", 32", 34", 36"	10'
Chimney Diameter (Inches)	Horizontal Support Spacing (Feet)
5", 6", 7", 8", 10", 12", 14", 16"	10'

Figure 18 - Horizontal Support Details

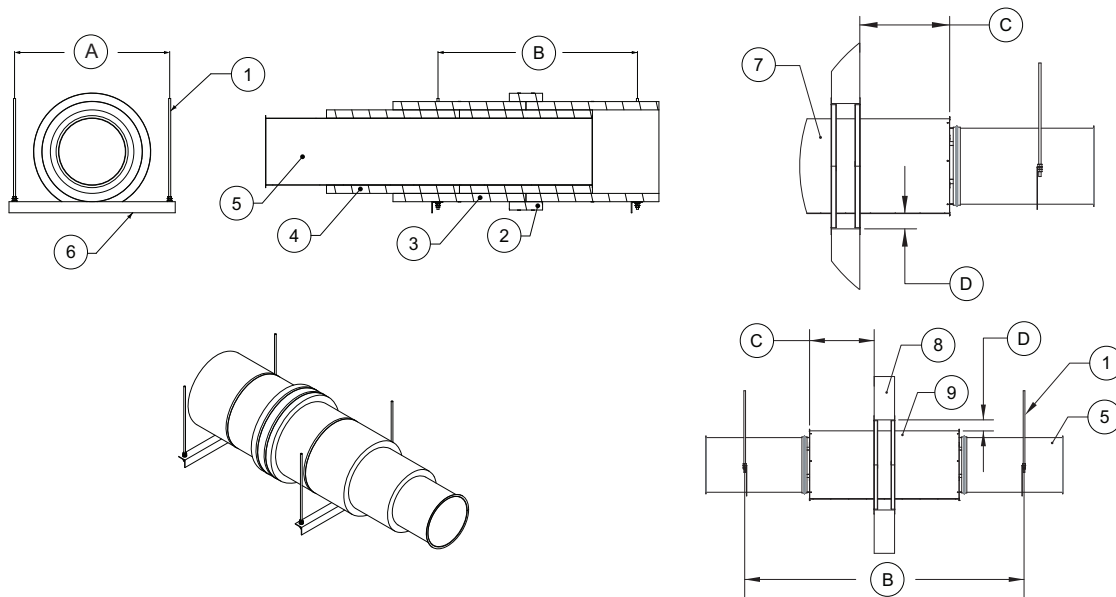

1. 1/2" Threaded Rod, by others
2. 6" Collar
3. Listed Duct Wrap Outer Layer (Grease Duct Only)
4. Listed Duct Wrap Inner Layer (Grease Duct Only)
5. Duct/Chimney
6. Angle/Unistrut
7. Double wall chimney may be removed if the clearance to combustibles is: UL103 Single wall = 18", UL2561 Single Wall = 36"
8. Wall
9. Double Wall Assembly
- A. Outside Diameter (OD) + 4"
- B. Horizontal Support Spacing, refer to **Table 9**
- C. Clearance to Combustibles (Shell to Joist), refer to "**Clearances - Chimney**" on page 16
- D. Clearance to Combustibles (Chimney to Ceiling/Wall), refer to "**Clearances - Chimney**" on page 16

Single Wall Vertical Support Spacing and Wall Guide Support

IMPORTANT: Vertical supports shown in this manual (Figure 19 through Figure 26) are recommended. Supports by others must be approved by the Manufacturer and AHJ. Support spacing must be as stated in this manual.

The Manufacturer will accept the grease duct's installation in a vertical chaseway without cleanouts along the enclosed vertical section as specified in NFPA 96, Chapter 7 - Exhaust Systems, 7.3.3 – “Openings shall not be required in portions of the duct accessible from the duct entry or discharge.” The duct run must be readily accessible from the top and bottom of the run, and it is acceptable to the Authority Having Jurisdiction (AHJ).

The wall guide is to be attached to Non-Combustible and Combustible surfaces. The wall guide is constructed of 12 gauge steel and is comprised of a full ring, brackets, angle struts, wall support plates, and hardware for assembly (includes mounting hardware to secure supports to gypsum walls constructed using 25 gauge steel studs), see Figure 19. The ring, which is split into two halves for ease of assembly, is constructed of 12 gauge steel. With the addition of a spacer between the two halves, the diameter is 1/8” larger than the outside diameter of the duct/chimney. This is to allow for thermal expansion.

The wall support should be installed at the joint of the duct/chimney and below the V-clamp so that the V-clamp moves away from the support ring. The wall guide assembly is designed for 2 to 18 inches of clearance from duct/chimney to non-combustible/combustible walls. The side struts may be placed either up or down, as is convenient. This assembly is intended to resist lateral or side loads only and is not for carrying the weight of the vertical duct/chimney. The horizontal struts allow for attachment to the wall after the duct/chimney has been positioned. The angle of attachment may vary as needed for the duct/chimney to wall clearance. Wall supports shall be used at the proper spacing shown in Table 10 for vertical duct/chimney support, with appropriate expansion joints to allow for thermal expansion and wall guides for lateral stability.

The curb/transition plate combination is to be attached to Non-Combustible and Combustible surfaces. The curb is constructed of 20 gauge aluminized steel. The curb has 3” flanges on the bottom, and 1” flanges on top. The bottom flanges are used to secure the curb to the roof substrate while the top 1” flange is used to strengthen the top of the curb where the fan is mounted, see Figure 25 and Figure 26 for details.

The transition plate is constructed of 16 gauge aluminized steel. There are three types of transition plates available TP, TPDB, and TPDBEX. TP is an oversized transition plate that can be cut to size in the field, TP is installed under the exhaust fan. TPDB is used when the duct is running through the curb and continuing above the plate. This plate has a 2” down bend to help seal the curb. TPDB is not used with exhaust fans. TPDBEX is designed to be used under the exhaust fan and not interfere with the fan base or hinge kits. TPDBEX is installed under the exhaust fan and does require an exact fit. The curb/transition plate combination is considered part of the vertical support system. The curb/transition plate combination support spacing is shown in Table 10. See “Transition Plate” on page 24 for more information on transition plates.

Table 10 - Single Wall Vertical Support Spacing

Grease Duct Diameter (Inches)	Vertical Wall Support Spacing (Feet)	Vertical Curb/Floor Support Spacing (Feet)
5”, 6”, 7”, 8”, 10”, 12”, 14”, 16”, 18”, 20”, 22”, 24”, 26”, 28”, 30”, 32”, 34”, 36”	10'	24'
Chimney Diameter (Inches)	Vertical Wall Support Spacing (Feet)	Vertical Curb/Floor Support Spacing (Feet)
5”, 6”, 7”, 8”, 10”, 12”, 14”, 16”	10'	24'

Vertical support systems must be attached only to the building structure or supported with rigid structural members. Refer to Table 10 for maximum support spacing. It is recommended that vertical support systems are attached to block, concrete, or steel with clearance that is adequate for installation and access.

Single Wall Vertical Wall Support (Wood, Concrete, Steel)

IMPORTANT: Vertical supports shown in this manual (Figure 19 through Figure 26) are recommended. Supports by others must be approved by the Manufacturer and AHJ. Support spacing must be as stated in this manual.

1. Determine the wall material (gypsum, wood, or concrete) where the duct/chimney will be installed.
2. Wall support plates are used to distribute weight when installed on gypsum. Support struts are used to support the duct/chimney assembly and to connect the wall support plates and brackets.
3. Locate the support bracket assembly. Verify there is no interference and that the clearance to combustibles is 18", or the duct system is wrapped using a UL Listed wrap.
4. Mark the location and drill clearance holes. Use supplied hardware to assemble supports.
5. To install supports to wall, use the appropriate hardware kit:
 - Use kit DWVESU-HARDWARE-CM for concrete or masonry wall construction
 - Use kit DWVESU-HARDWARE-S for steel gauge wall construction
 - Use kit DWVESU-HARDWARE-W for wooden wall construction
6. Make sure the duct/chimney V-clamp is installed above the support ring.

Figure 19 - Vertical Wall Support Grease Duct (5"-24")/Chimney (5"-16")

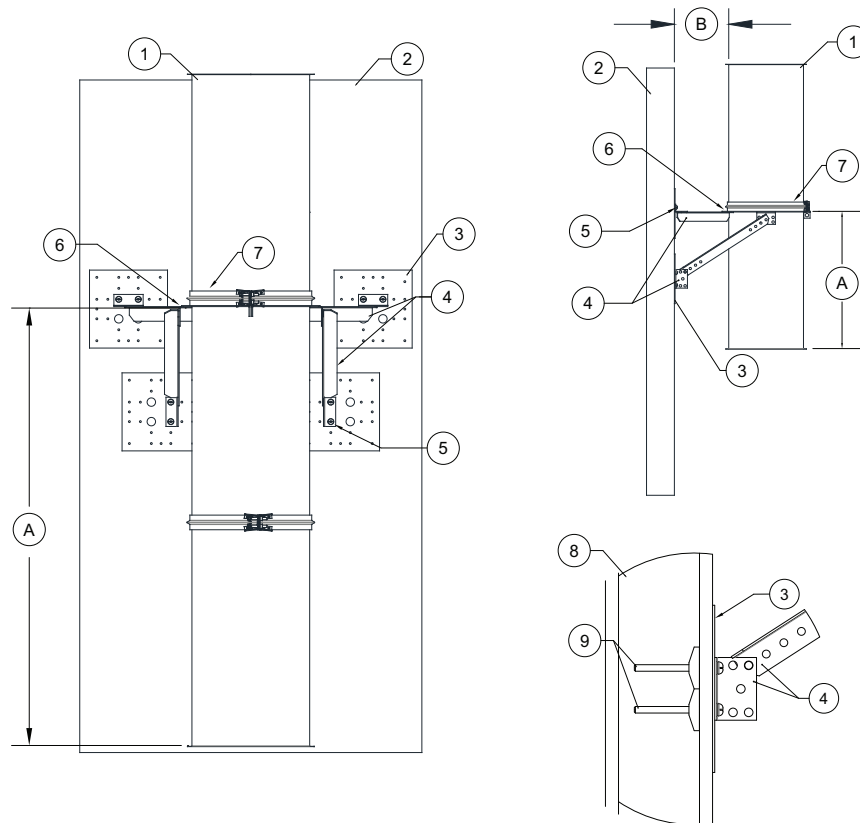

1. Duct/Chimney.
 2. Wall Material (Gypsum, Wood, Concrete).
 3. Wall Support Mounts.
 4. Support Struts.
 5. 5/16"-18 (hardware by others).
 6. Support Ring.
 7. "V" Clamp.
 8. Open Wall.
 9. 5/16" x 4" Long Toggle Bolts - used for open wall cavities.
- A. Vertical Support Spacing, refer to **Table 10 on page 27**.
- B. Uninsulated duct must be 18" from Combustible Surface.

IMPORTANT: Vertical supports shown in this manual (Figure 19 through Figure 26) are recommended. Supports by others must be approved by the Manufacturer and AHJ. Support spacing must be as stated in this manual.

Figure 20 - Additional Wall Support Details Grease Duct (26"-36")

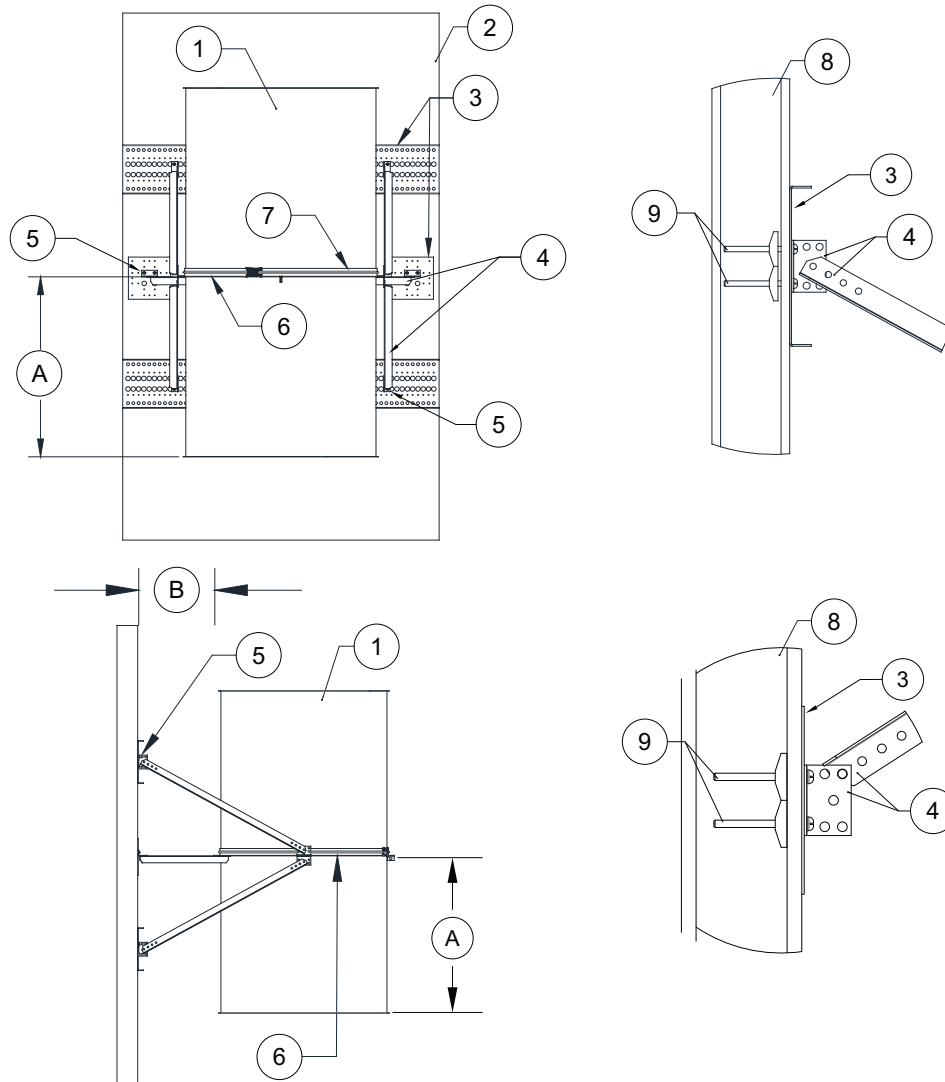

- | | |
|---|---|
| <ol style="list-style-type: none"> 1. Duct. 2. Wall Material (Gypsum, Wood, Concrete). 3. Wall Support Mounts. 4. Support Struts. 5. 5/16"-18 Hardware by Others. 6. Support Ring. 7. "V" Clamp. | <ol style="list-style-type: none"> 8. Open Wall. 9. 5/16" x 4" Long Toggle Bolts - used for open wall cavities. <p>A. Vertical Support Spacing, refer to Table 10 on page 27.</p> <p>B. Uninsulated duct must be 18" from Combustible Surface.</p> |
|---|---|

IMPORTANT: Vertical supports shown in this manual (Figure 19 through Figure 26) are recommended. Supports by others must be approved by the Manufacturer and AHJ. Support spacing must be as stated in this manual.

Figure 21 - Vertical Support Details

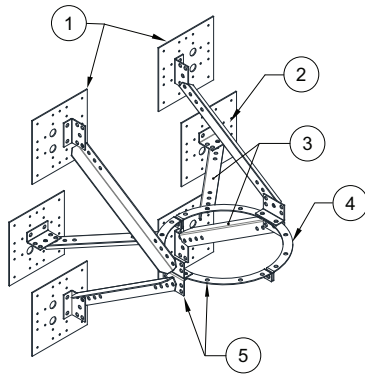

5'-24" Vertical Support Shown

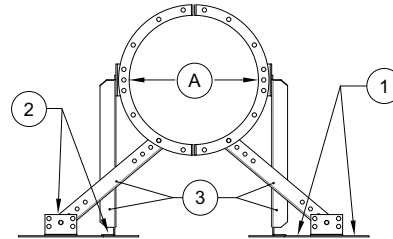

5'-24" Vertical Support Shown

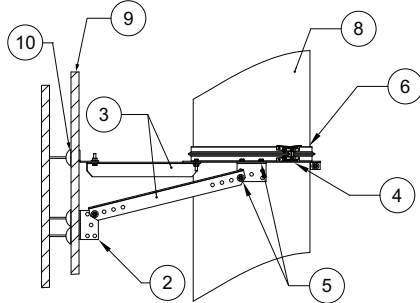

26"-36" Vertical Support Shown

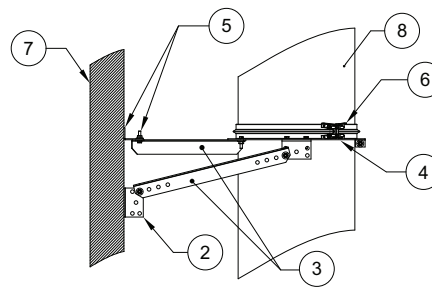

26"-36" Vertical Support Shown

1. Additional Wall Support for 30"/36".
2. Standard Wall Support Grease Duct (5"-36")/
Chimney (5"-16")
3. Strut.
4. Full Support Ring.
5. 5/16"-18 Hardware by Others.

6. V-clamp.
7. Solid Wall.
8. Duct.
9. Open Wall Gypsum.
10. 5/16" x 4" Toggle Bolt - used for open wall
cavities.

Single Wall Floor Support

IMPORTANT: Vertical supports shown in this manual (Figure 19 through Figure 26) are recommended. Supports by others must be approved by the Manufacturer and AHJ. Support spacing must be as stated in this manual.

Figure 22 - Duct Ceiling Support

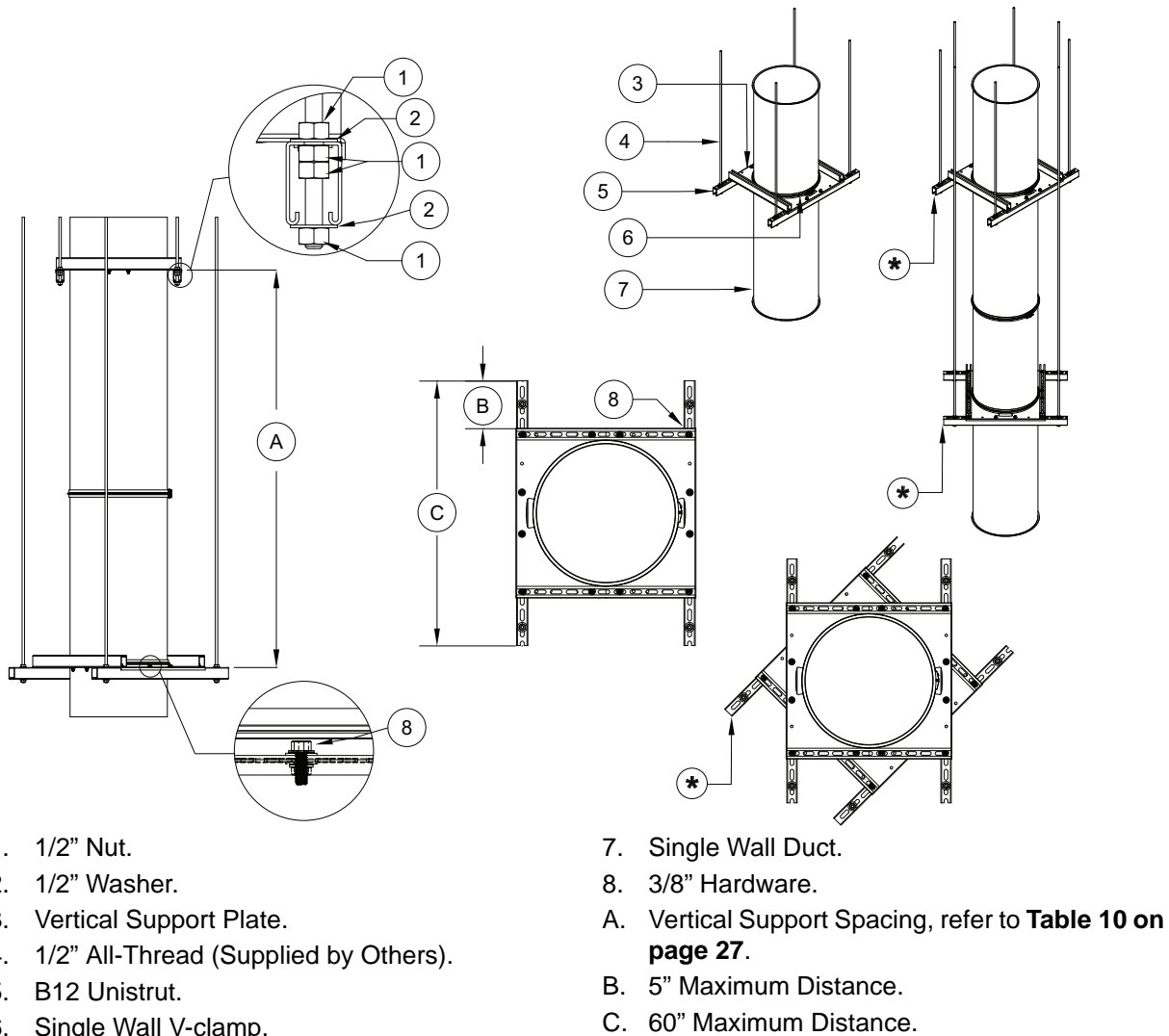

* Supports must be rotated so that all-thread is attached directly to the ceiling. **DO NOT ATTACH ALL-THREAD FROM ONE UNISTRUT TO ANOTHER.**

IMPORTANT: Vertical supports shown in this manual (Figure 19 through Figure 26) are recommended. Supports by others must be approved by the Manufacturer and AHJ. Support spacing must be as stated in this manual.

Figure 23 - Chase Floor Grease Duct Support

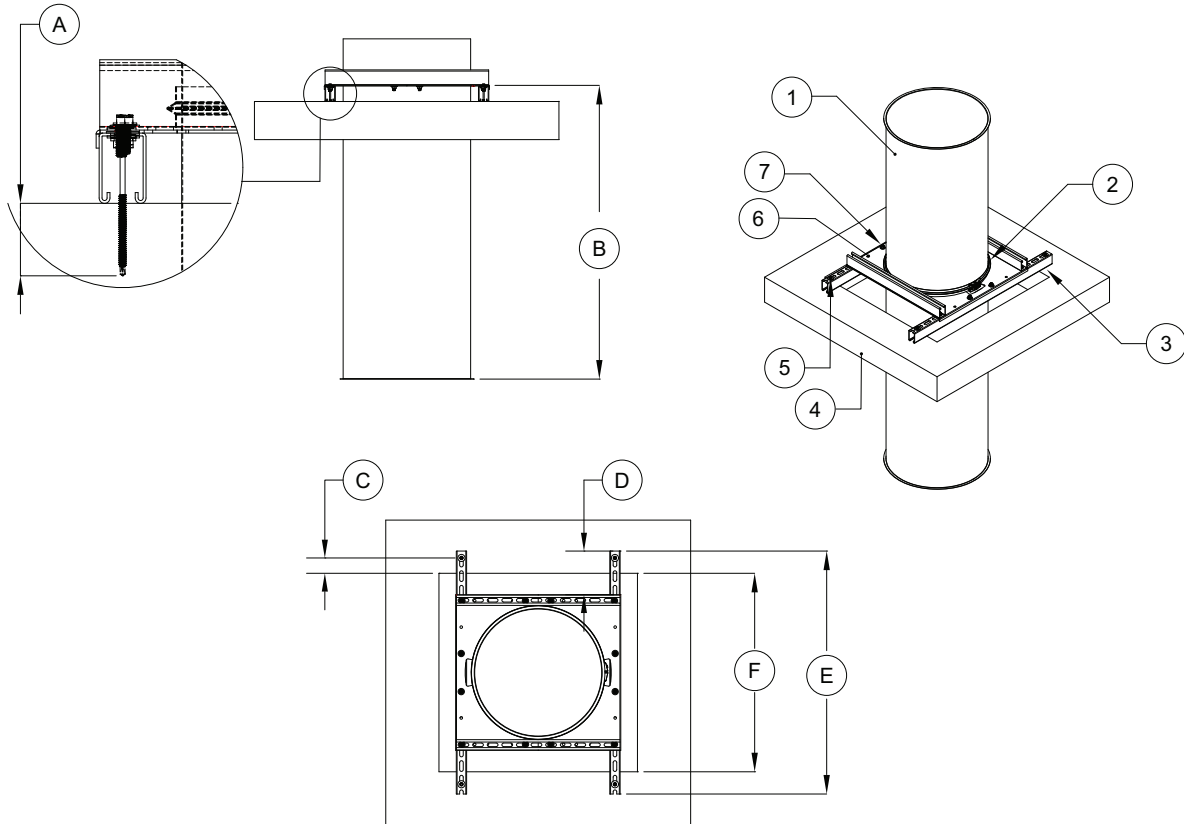

- | | |
|--|--|
| <ul style="list-style-type: none"> 1. Single Wall Duct. 2. Single Wall V-clamp. 3. B12 Strut. 4. Substrate. 5. Substrate Fastener, refer to Table 11. 6. Vertical Support Plate. 7. 3/8" Hardware. | <ul style="list-style-type: none"> A. Minimum Thread Penetration, refer to Table 11. B. Vertical Support Spacing, refer to Table 10 on page 27. C. Minimum Edge Distance, refer to Table 11. D. 5" Maximum Distance. E. 60" Maximum Distance. F. Open Area Chase. |
|--|--|

Table 11 - Substrate Hardware

Decking Material	Hardware	Minimum Thread Penetration	Minimum Edge Distance
Wood - Minimum G.42	Zinc Plated Steel Hex Head Lag Screw 3/8" x 2-1/2" with 3/8" washer	2"	1-1/2"
Concrete - 2500 Minimum PSI	Hilti Kwik Bolt - 3/8" Diameter TZ Expansion Anchor with 3/8" washer	2-5/16"	3"
Steel Roof Truss	Dri-Flex Self-Drilling Screws 1/4"-14 Min. 1/2" Through with 1/4" washer	12 Gauge or 1/8" Thick	3/8"

Figure 24 - Chase Floor Support Chimney

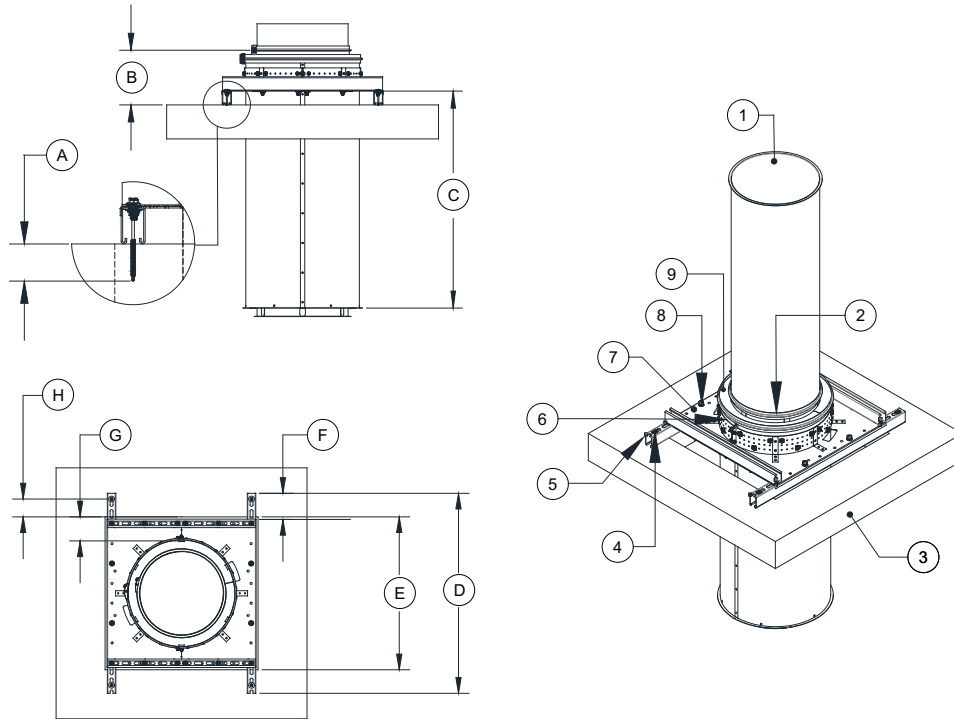

- | | |
|---|--|
| <ul style="list-style-type: none"> 1. Chimney. 2. Single Wall V-band. 3. Substrate. 4. Substrate Fastener, refer to Table 12. 5. B12 Unistrut. 6. Floor Support Band. 7. Vertical Support Plate. 8. 3/8" Hardware. 9. Single Wall V-band and End Cap. | <ul style="list-style-type: none"> A. Minimum Thread Penetration, refer to Table 12. B. Clearance to Combustibles (Chimney to Ceiling/Wall), refer to Table 7 on page 16. C. Vertical Support Spacing, refer to Table 10 on page 27. D. 60" Maximum Distance. E. Minimum Open Area Chase, refer to Table 12. F. 5" Maximum Distance. G. Clearance to Combustibles (Shell to Joist), refer to Table 7. H. Minimum Edge Distance, refer to Table 12. |
|---|--|

Table 12 - Substrate Hardware

Decking Material	Hardware	Minimum Thread Penetration	Minimum Edge Distance	Minimum Open Chase Area
Wood - Minimum G.42	Zinc Plated Steel Hex Head Lag Screw 3/8" x 2-1/2" with 3/8" washer	2"	1-1/2"	For 4" = 12-1/2" For 5" = 13-1/2" For 6" = 14-1/2" For 7" = 15-1/2" For 8" = 16-1/2" For 10" = 18-1/2" For 12" = 20-1/2" For 14" = 22-1/2" For 16" = 26-1/2"
Concrete - 2500 Minimum PSI	Hilti Kwik Bolt - 3/8" Diameter TZ Expansion Anchor with 3/8" washer	2-5/16"	3"	
Steel Roof Truss	Dril-Flex Self-Drilling Screws 1/4"-14 Min. 1/2" Through with 1/4" washer	12 Gauge or 1/8" Thick	3/8"	

IMPORTANT: Vertical supports shown in this manual (Figure 19 through Figure 26) are recommended. Supports by others must be approved by the Manufacturer and AHJ. Support spacing must be as stated in this manual.

Figure 25 - Vertical Curb Support Details View 1

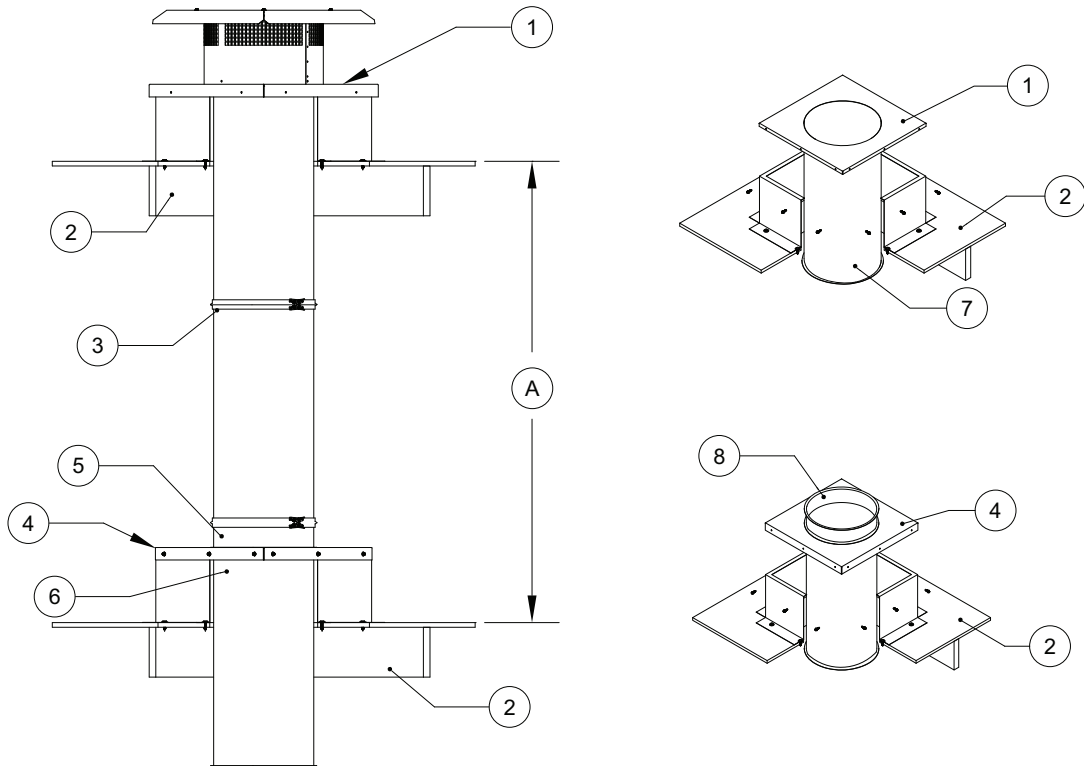

1. Transition plate (TPDBEX) is designed to mount under the unit.
2. Decking Floor/Roof - Wood, Concrete, or Steel.
3. Straight duct section with V-clamp.
4. Transition plate (TPDB) is designed to be secured to duct when going through curb.
5. When duct is installed through the curb, the riser or fitting is welded above the TPDB.
6. When duct is installed through the curb, the duct is welded below the TPDBEX.
7. Straight duct welded to transition plate.
8. Riser or fitting welded to TPDBEX.
- A. Vertical Support Spacing, refer to **Table 10 on page 27**.

IMPORTANT: Vertical supports shown in this manual (Figure 19 through Figure 26) are recommended. Supports by others must be approved by the Manufacturer and AHJ. Support spacing must be as stated in this manual.

Figure 26 - Vertical Curb Support Details View 2

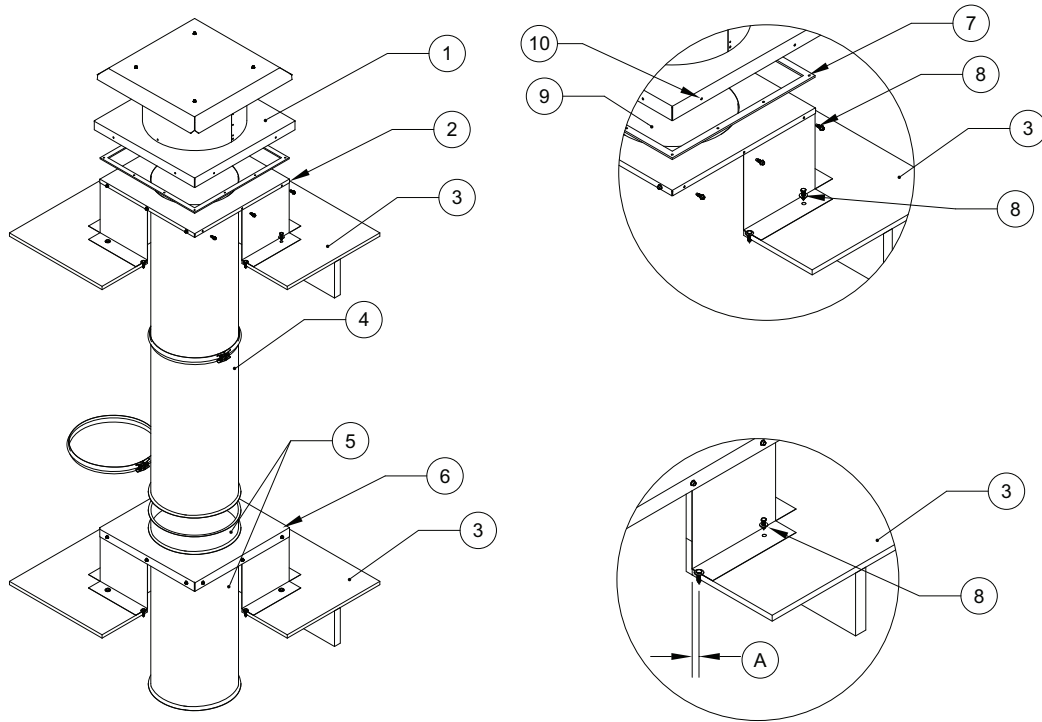

1. Gravity Vent.
2. Transition plate (TPDBEX) is designed to mount under the unit.
3. Decking Floor/Roof - Wood, Concrete, or Steel.
4. Straight duct section with V-clamp.
5. When duct is installed through the curb, the riser or fitting is welded above the TPDB.
6. Transition plate (TPDB) is designed to be secured to duct when installed through curb.
7. When duct is installed through the curb, the duct is welded below the TPDB.
8. Substrate Hardware, refer to **Table 11 on page 32**.
9. Inner duct fully welded to the transition plate. All welds are factory dye tested.
10. Unit is secured to the vented curb. Use 1/4"-20 x 2" zinc plated self-drilling screws.
11. High temperature gasket used to seal unit to the transition plate.
12. The transition plate is secured to the curb using 1/4"-20 x 1-1/2" zinc plated self-drilling screws.
- A. Minimum Edge Distance, refer to **Table 11**.

IMPORTANT: Vertical supports shown in this manual are recommended. Supports by others must be approved by the Manufacturer and AHJ. Support spacing must be as stated in this manual.

Figure 27 - Vertical Curb Support Details View

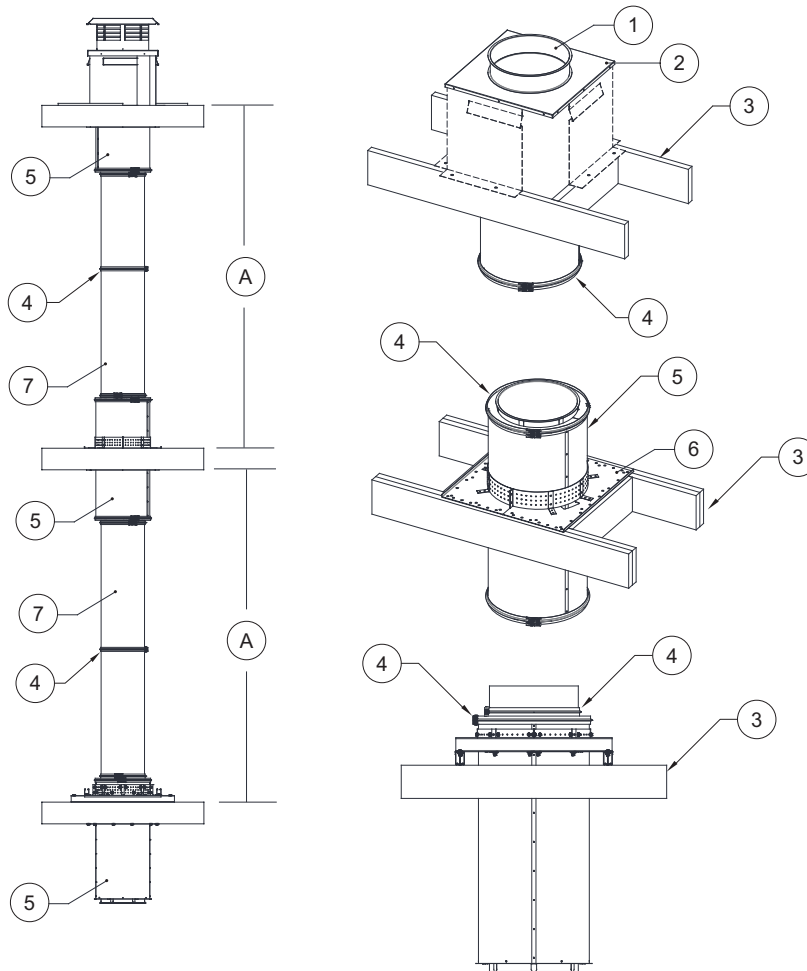

1. Riser or fitting welded to transition plate.
2. Transition Plate.
3. Decking Floor/Roof - Wood, Concrete, or Steel.
4. V-band.
5. Through Penetration 2R Double Wall Assembly.
6. Floor Support Assembly.

7. Single Wall Section.
- A. Vertical Support Spacing, refer to **Table 10 on page 27.**

Grease Duct Assembly Examples

The illustrations shown provide useful information on the installation of grease duct systems. Each installation is specific to the application and the jobsite. When duct systems are installed outside, welded seams must be painted with corrosion-resistant high-temperature paint. If you encounter a situation not covered by this illustration, refer to the guide or consult the factory. Remember, if the distance to a combustible surface is less than 18 INCHES, you will need to wrap the duct in a UL Listed duct wrap to get "ZERO CLEARANCE TO COMBUSTIBLES."

Adjustable ducts and standard ducts can be used to terminate at the transition plate. The duct is fully welded to the transition plate at the factory.

Adjustable ducts are used on runs over 100 feet to compensate for thermal expansion. The duct will grow approximately 1" per 100 feet of duct length for each 100°F exhaust vapor temperature above the surrounding air temperature.

Figure 28 - Grease Duct Installation Guide Details View 1

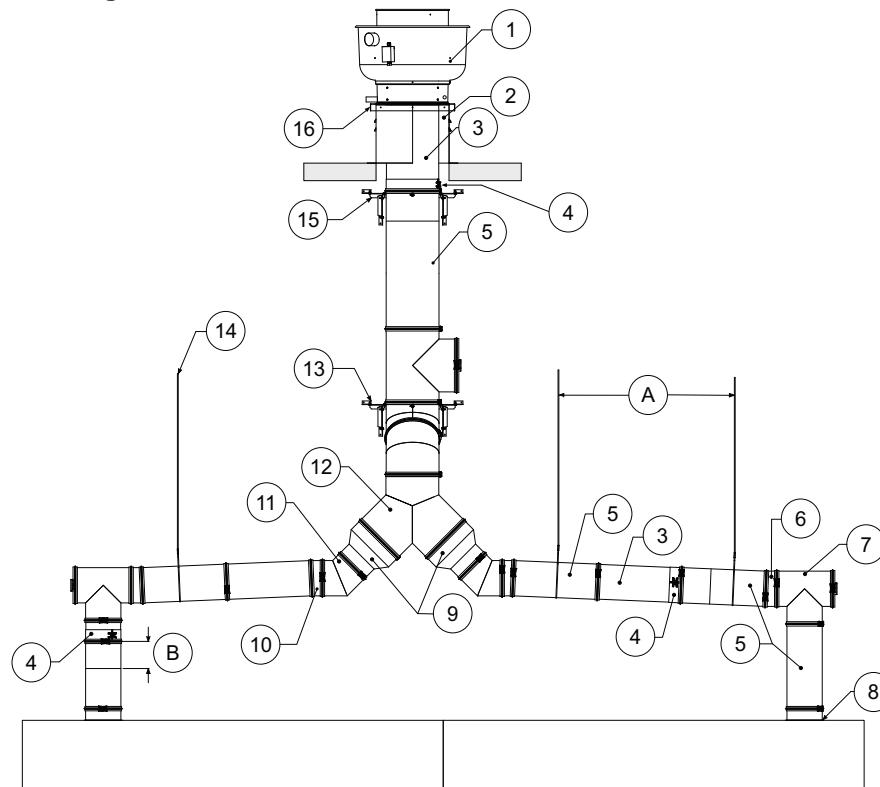

- | | |
|--|---|
| 1. Exhaust Fan | 12. Y Tee |
| 2. Vented Curb per NFPA 96 | 13. First vertical support at joint #1 after a change in direction. Support is mounted under V-clamp. |
| 3. Adjustable Duct | 14. 1/2" All-Thread Rod |
| 4. Adjustable Collar | 15. The vertical support assembly is designed for 2" to 18" clearance from duct to non-combustible surface. Support is mounted under V-clamp. |
| 5. Standard Duct | 16. Transition plate with ceramic gasket. |
| 6. Offset Collar | A. Horizontal Support Spacing, refer to Table 9 . |
| 7. Tee with Access Door - Access doors are used when there is a change in direction, or when areas of the duct are not accessible. | B. Minimum Overlap, refer to Table 2 . |
| 8. Riser | |
| 9. Adapter | |
| 10. Offset collar used to pitch horizontal duct runs. | |
| 11. 45° Elbow | |

Figure 29 - Grease Duct Installation Guide Details View 2

1. Exhaust Fan
 2. Vented Curb per NFPA 96
 3. Adjustable Duct
 4. Adjustable Collar
 5. Standard Duct
 6. V-clamp
 7. Tee Assembly with Access Door - Access doors are used when there is a change in direction, or when areas of the duct are not accessible.
 8. 45° Elbow
 9. Access Door
 10. Riser
 11. The vertical support assembly is used at the first connection after the change of direction
 12. The vertical support assembly is designed for 2" to 18" clearance from duct to non-combustible surface.
 13. Transition plate with ceramic gasket.
- A. Minimum Overlap, refer to **Table 2**.
 B. Vertical Support Spacing, refer to **Table 10**.
 C. Hood Height
 D. Floor to bottom of hood height
 E. Appliance to bottom of hood height 33" minimum/ 48" maximum
 F. Hood Width

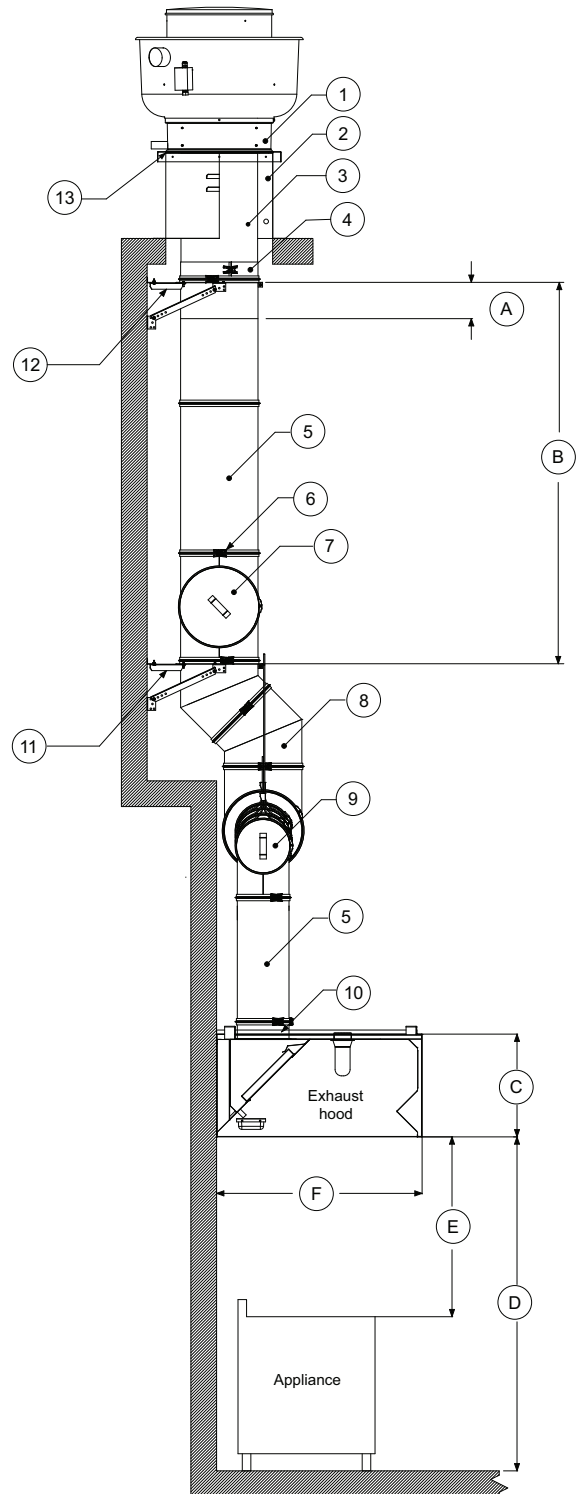
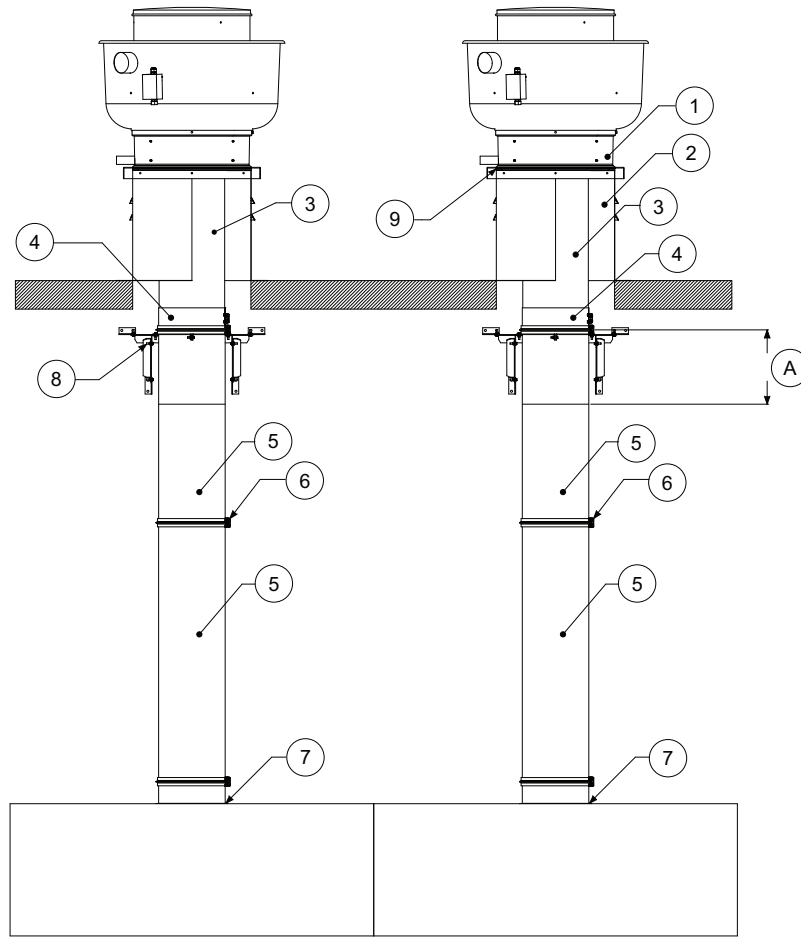

Figure 30 - Grease Duct Installation Guide Details View 3



- | | |
|--|---|
| <ul style="list-style-type: none"> 1. Exhaust Fan 2. Vented Curb per NFPA 96 3. Adjustable Duct 4. Adjustable Collar 5. Standard Duct 6. V-clamp 7. Riser | <ul style="list-style-type: none"> 8. The vertical support assembly is designed for 2" to 18" clearance from duct to non-combustible surface. The vertical support is mounted under the V-clamp and adjustable collar. 9. Transition plate with ceramic gasket. A. Minimum Overlap, refer to Table 2. |
|--|---|

Chimney Assembly Examples

There is no limit on the angle or slope of an offset for gas or liquid fuel burning appliances, but with a solid fuel burning appliance the slope must not be greater than 30 degrees (USA) or 45 degrees (Canada) from vertical.

Chimney for combination fuel heating appliances which are capable of burning solid fuel or are convertible to solid fuel are limited to the same 30 degrees (USA) or 45 degrees (Canada) slope even if the current choice of fuel is gas or oil.

Figure 31 - Vertical Details for Chimney Applications

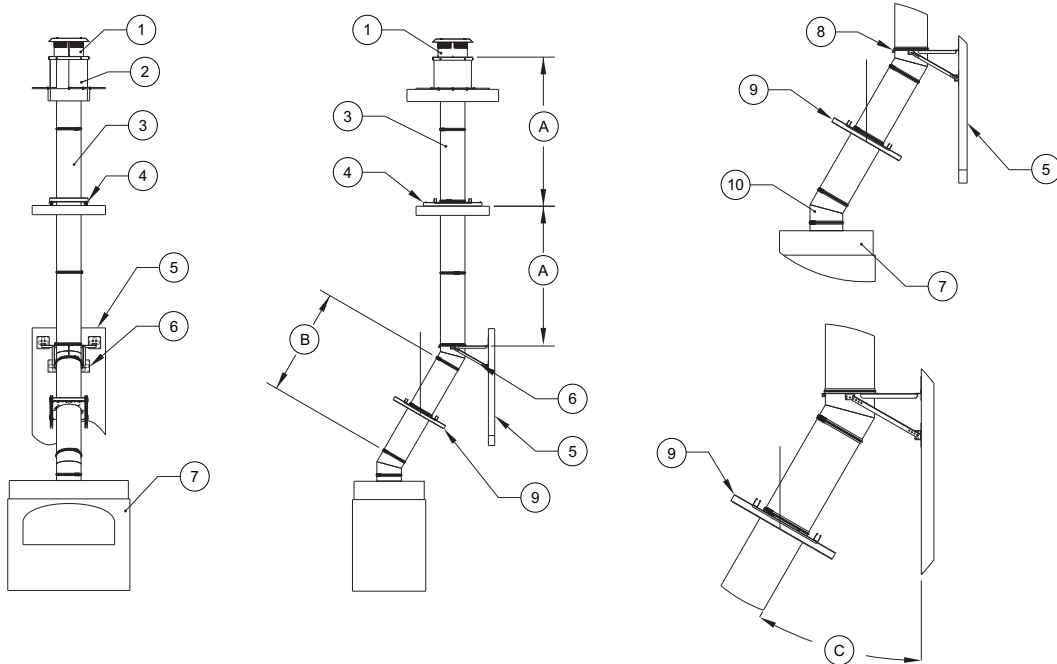

1. Base Cap
2. Vented Curb
3. Chimney Section
4. Vertical Floor Support
5. Wall
6. Vertical Wall Support Kit
7. Equipment
8. V-band

9. Hanging Support with 1/2" All-Thread Rod
10. Equipment Adapter
- A. Vertical Support Spacing, refer to **"Single Wall Vertical Support Spacing"** on page 27
- B. Maximum Straight Length = 8 Feet
- C. Maximum angle not to exceed when being used with solid fuel chimney applications - 30° USA / 45° Canada

Methods Used to Test After Assembly

NOTE: The mentioned leakage tests are not specific to the listing(s) requirements of the system being tested. Local codes and regulations should be consulted before final inspection. In the absence of local codes and regulations, refer to the latest edition of the International Mechanical Code (IMC) Chapter 5, Exhaust Systems for inspection and testing requirements.

Method 1 - Light Test per IMC 506.3.2.5

Prior to the concealment of any portion of a duct system, a leakage test shall be performed. Ducts shall be considered to be concealed where installed in shafts or covered by coatings or wraps that prevent the system from being visually inspected on all sides. The permit holder shall be responsible to provide the necessary equipment and perform a system leakage test. A light test shall be performed to determine that all welded and brazed joints are liquid-tight.

A light test shall be performed by passing a lamp having a power rating of not less than 100 watts through the entire duct section to be tested. The lamp shall be open so as to emit light equally in all directions perpendicular to the duct walls. A test shall be performed for entire duct system, including the hood-to-duct connection. The system shall be permitted to be tested in sections, provided that every joint is tested. For listed factory-built grease ducts, this test shall be limited to duct joints assembled in the field and shall exclude factory welds.

Method 2 - Smoke Test

NOTE: Materials or chemicals used for smoke testing should not be corrosive to stainless steel. Smoke generating equipment containing chlorine or chlorinated chemicals must not be used. Consult the factory for any questions regarding the smoke equipment and duct compatibility.

EXCEPTION: When performing a Capture and Containment (C&C) test on a ventilation hood, smoke candles (cartridges) are allowed. Only use non-toxic smoke with low chloride concentration <20%. Testing should be conducted with all exhaust fans running to dilute the air.

After installing the duct, allow the listed sealant to cure for a minimum of 24 hours. Place the smoke equipment at the bottom of the duct system. The natural upward draft will pull the smoke to the top of the duct system. Various length duct runs may require multiple smoke tests. Once the smoke has reached the top of the duct run, cap the duct securely. Inspect all joints for leakage.

Method 3 - Pressure Testing per SMACNA's HVAC Air Duct Leakage

A pressure test shall be performed during initial installation by the permit holder or its testing agency using the appropriate local code testing procedure. This test must be performed as a rough inspection before being covered, concealed, insulated, or wrapped before final installation to the exhaust fan, kitchen exhaust hood, or other equipment.

All single wall joint connections have been tested to Seal Class A, Leakage Class 1 specifications per SMACNA's HVAC Air Duct Leakage Test Manual. In the absence of local code testing procedures, use SMACNA's HVAC Air Duct Leakage Test Manual for inspection and testing guidelines. Recommended Air Leakage Tester: Dalt Model 6900. Refer to **Figure 32**.

NOTE: If the duct system is modified or altered, the entire system will require re-testing.

Figure 32 - Leakage Test

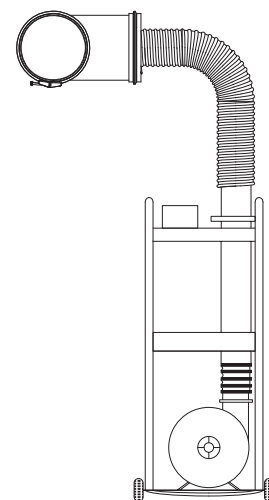

General Duct Weight

Two different material gauges are available, 20 gauge is the minimum / 18 gauge is the maximum allowable material per this listed duct. Both gauges have been tested by ETL and comply with standard UL-1978. 20 gauge is the standard material used in application with 18 inches or more to combustible surfaces. 20 gauge duct may also be wrapped using a listed duct wrap for zero clearance to combustibles, 18 gauge is required in some Authority Having Jurisdictions (AHJs) when duct needs to be wrapped using a listed duct wrap for zero clearance to combustibles.

Weight – 20 Gauge Duct

The following formula can be used to approximate the weight of total lengths of duct for 20 GA duct ($.0327 \times "L" \times "D"$). "L" and "D" should be calculated in inches, where L is the length and D is the diameter. Example: A total length of duct is 25 ft long, 14" diameter ($.0327 \times (25' \times 12") \times 14" = 137 \text{ LBS}$).

Weight – 18 Gauge Duct

The following formula can be used to approximate the weight of total lengths of duct for 18 GA duct ($.0417 \times "L" \times "D"$). "L" and "D" should be calculated in inches, where L is the length and D is the diameter. Example: A total length of duct is 25 ft long, 14" diameter ($.0417 \times (25' \times 12") \times 14" = 175 \text{ LBS}$).

As a result of our dedication to constant improvements and quality, the MANUFACTURER reserves the right to update specifications without notice. Please refer to MANUFACTURER'S website for up to date documentation.

Scan QR Code for Online Manual

